

Mastertech
7120

型式名 7120

クローラクレーン

最大定格総荷重 120t × 5.0m

▶主要諸元	1
▶フック巻上限界	1
▶仕様とアタッチメント	1
クローラクレーン	
▶全体図	2
▶ブーム構成	3
▶ロングブーム構成/ジブ構成	4
▶作動範囲図	5, 6
▶定格総荷重	6
▶主ブーム/補助シーブ定格総荷重表	7
▶ロング主ブーム/ロング補助シーブ定格総荷重表	8
▶ジブ定格総荷重表	9~12
ラフティングタワー	
▶全体図	13
▶タワー構成	14
▶タワージブ構成	14
▶定格総荷重	15
▶タワー長さ30.4m	16
▶タワー長さ33.4m	17
▶タワー長さ36.5m	18
▶タワー長さ39.5m	19
▶タワー長さ42.5m	20
▶タワー長さ45.6m	21
▶タワー長さ48.6m	22
▶タワー長さ51.7m	23
▶標準装備品/オプション装備品	24

▶主要諸元 (型式: 7120)

項目	仕様	仕様	
		クローラクレーン	ラフティングタワー
最大つり上げ能力	t×m	120×5.0	20×15.0
ブーム(タワー)長さ	m	15.2~61.0	30.4~51.7
		61.0~79.2(ロング)	
ジブ(タワージブ)長さ	m	12.2~30.5	22.9~44.2
最大ブーム(タワー)+ジブ(タワージブ)長さ	m	61.0+30.5	51.7+44.2
ロープ速度	主巻	m/min	*120~3
	補巻	m/min	*120~3
	タワージブ起伏	m/min	-
	ブーム(タワー)起伏	m/min	*48~2
	サード(オプション)	m/min	*120~3
旋回速度	min ⁻¹ {rpm}	2.1{2.1}	
走行速度	km/h	*1.3/0.9	
作業時質量(基本姿勢)	t	120	130
接地圧(基本姿勢)	kPa{kgf/cm ² }	94{0.96}	102{1.04}
登坂能力(tanθ)	%(度)	30{16.7}	-
定格ラインプル	kN{tf}	118{12.0}	-
エンジン	名称	三菱6D24-TLE2A	
	定格出力	kW/min ⁻¹ {PS/rpm}	
ワイヤロープ	主巻	mm	φ26
	補巻(タワージブ)	mm	φ26
	ブーム(タワー)	mm	φ20

各ロープ速度はドラム1層目での値です。

*印の速度は軽負荷の時の値であり、負荷により速度の変動があります。
単位は国際単位系のS I単位で、{ }内は従来表示です。

▶フック巻上限界 (単位: m)

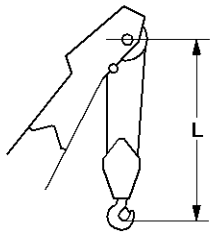

使用フック	L
120tフック	5.0
70tフック	5.0
35tフック	5.0

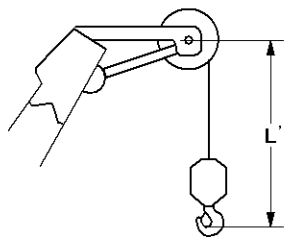

使用フック	L'
12tボールフック	4.2

▶仕様とアタッチメント (クローラクレーン/ラフティングタワー)

アタッチメント	仕様	
	クローラクレーン	ラフティングタワー
4.6m上部ブーム	◎	-
3.0m中間テーパーブーム*1	◎	-
1.4mタワーキャップ	-	◎
7.6m下部ブーム(共用)	◎	
3.0m中間ブーム(ケーブルローラ付・共用)	○	◎
6.1m中間ブーム(ケーブルローラ付・共用)	○	○
9.1m中間ブーム(ケーブルローラ付・共用)*2	○	◎
9.1mタワー専用中間ブーム	○兼用可	◎
4.6m上部ジブ	○	-
4.6m下部ジブ	○	-
3.1m中間ジブ	○	-
6.0m中間ジブ	○	-
7.6m上部タワージブ*3	△	◎
6.1m下部タワージブ	-	◎
3.0m中継ジブ*4	△	◎
3.0m中間タワージブ*5	△	◎
6.1m中間タワージブ*5	△	◎
9.1m中間タワージブ*5	△	○
120tフック(5枚シーブ)	◎	-
70tフック(3枚シーブ)	○	-
35tフック(1枚シーブ)	○	◎
12tボールフック	○	
12t軽量ボールフック(自重100kg)	○	-
補助シーブ	○	-
主巻ワイヤロープ(φ26×270m)	◎	-
補巻ワイヤロープ(φ26×250m)	○	-
ブーム(タワー)起伏ワイヤロープ(φ20×190m)	◎	◎
タワー主巻ワイヤロープ(φ26×290m)	-	◎
タワージブ起伏ワイヤロープ(φ26×290m)	-	◎
タワーブーム起伏ワイヤロープ(φ20×145m)	-	◎

◎印は基本仕様、○印は選択可能なアタッチメントを示します。

△印はロングブームを構成する場合に必要なアタッチメントを示します。

*1 クローラクレーンの上部ブームまたはラフティングタワー3.0m中継ジブとセットで使用します。

*2 クローラクレーンの中間ブームに転用できます。

*3 ロングブーム仕様では上部ブームとして使用します。

*4 ロングブーム仕様では3.0mテーパーブームと、ラフティングタワーでは下部タワージブとセットで使用します。

*5 ロングブーム仕様で中間ブームとして使用します。

クローラクレーン

▶全体図 (単位: mm)

縮尺: 約 1/150

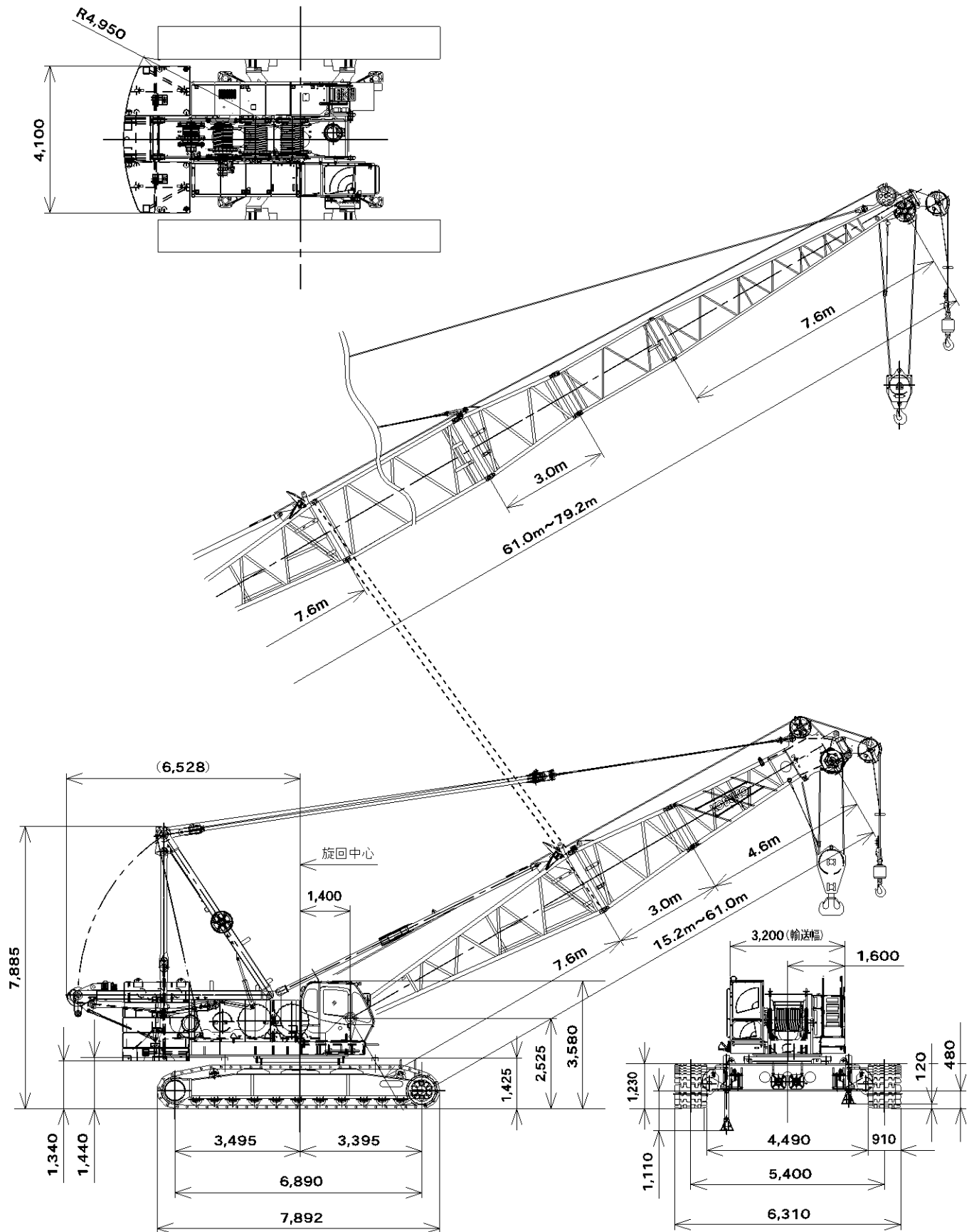

▶ブーム構成

- ↗ 印は、ジブ使用時のガイドライン取付位置を示します。
- ※印は、これより短いブームの組立可能な構成を示します。
- 使用するガイドラインの径はφ30mmです。

中間ブームの種類		
記号	ブーム長さ	備考
3.0	3.0m	ブーム
6.1	6.1m	ブーム
9.1	9.1m	ブーム
3.0T	3.0m	テーパーブーム
3.0A	3.0m	中継ジブ
3.0	3.0m	タワージブ
6.1	6.1m	タワージブ
9.1	9.1m	タワージブ

ブーム長さ m (ft.)	ブーム構成
15.2 (50)	
18.3 (60)	*
21.3 (70)	*
24.4 (80)	*
27.4 (90)	*
30.5 (100)	*
33.5 (110)	*
36.6 (120)	*
39.6 (130)	*

ブーム長さ m (ft.)	ブーム構成
42.7 (140)	*
45.7 (150)	*
48.8 (160)	*
51.8 (170)	*
54.9 (180)	*
57.9 (190)	*
61.0 (200)	*

▶ロングブーム構成

- ※印は、これより短いブームの組立可能な構成を示します。
- 使用するガイラインの径はφ30mmです。

ブーム長さ m (ft.)	ブーム構成/ロング
61.0 (200)	
64.0 (210)	※
67.1 (220)	※
70.1 (230)	
73.2 (240)	※
76.2 (250)	
79.2 (260)	

▶ジブ構成

- ジブを装着できる主ブームの長さは、24.4m (80) ~ 61.0m (200) です。

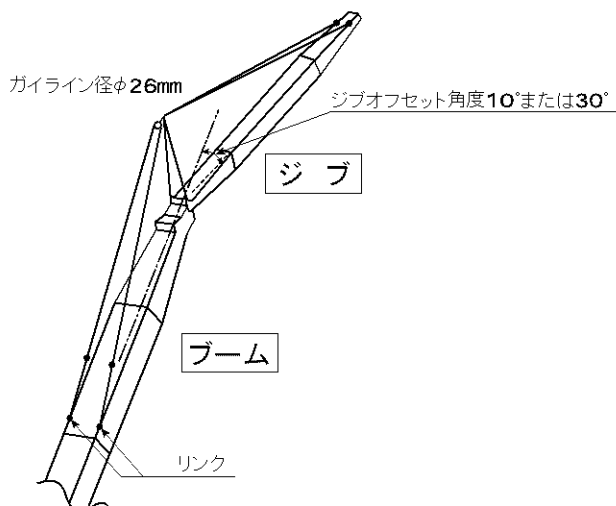

ジブ長さ m (ft.)	ジブ構成
12.2 (40)	
18.3 (60)	
24.4 (80)	
30.5 (100)	

▶作動範囲図

■主ブーム

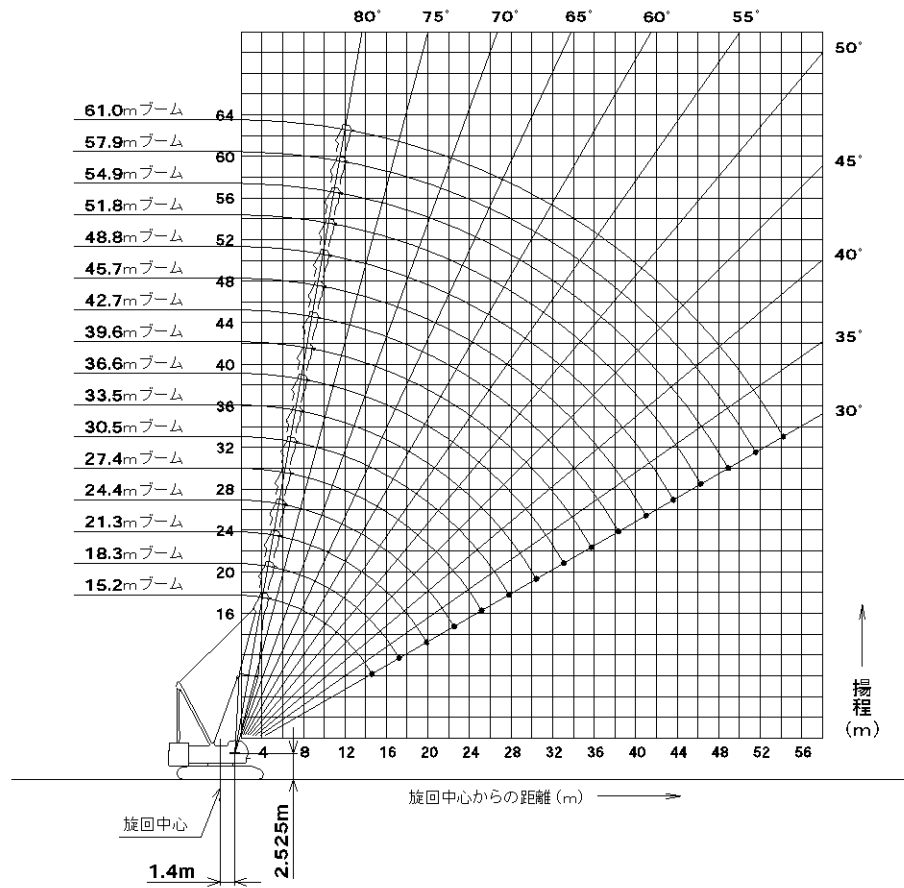

▶ロングブーム

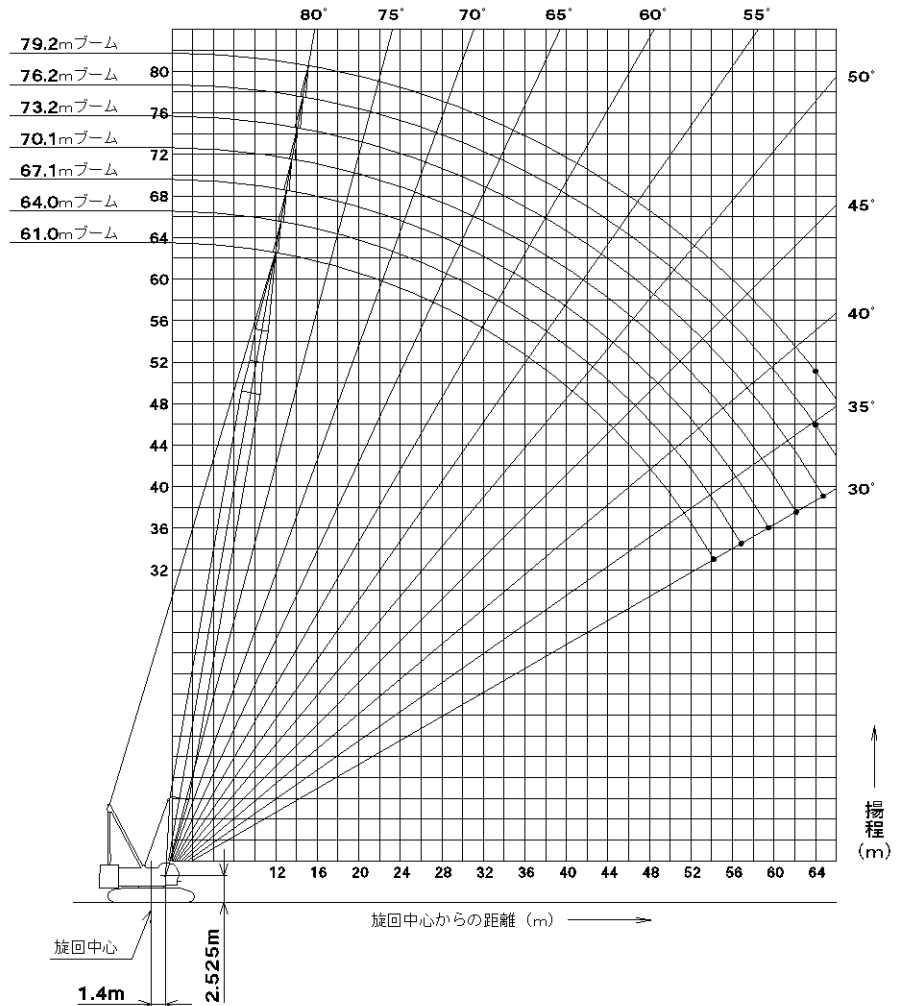

■ジブ装着
(オフセット角度10°/30°)

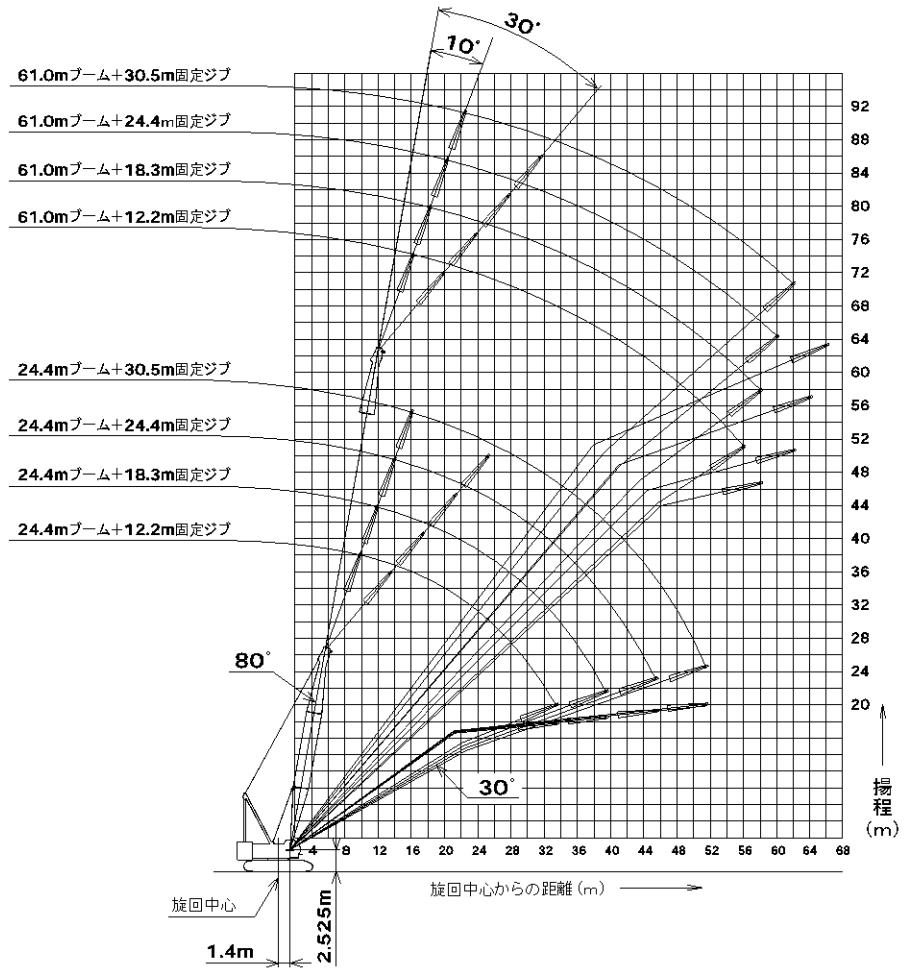

■定格総荷重

- 定格総荷重とは、水平堅土上における転倒荷重の78%以内で、フックブロック、玉掛用ワイヤロープ等のつり具の質量を含んだ値です。
- 作業半径とはクレーン旋回中心よりつり上荷重の重心までの水平距離を意味します。
- 実際につり上げ得る荷重は定格総荷重から（フック+玉掛用ワイヤロープ等のつり具）の質量を差し引いた値になります。
- 定格総荷重をつる場合にも風の影響、地盤の状態、作業速度その他安全作業に有害な状況がある時はオペレータは荷重の軽減、作業速度を遅くするなど状況に応じた判断をする責任があります。
- 表中の空欄の個所では作業を行うことができません。
- クレーン作業中には必ずガントリを最高位置に立ててください。
- すべてのブーム（ジブ）長さにおける中間ブーム（ジブ）の構成は取扱説明書の指示を厳守してください。
- 主ブームに補助シーブを取り付けたままで主フックを使用する場合の定格総荷重は、主ブーム定格総荷重から、一律0.8t差し引いた値となります。ただし最小定格総荷重は2.0tとします。
- 補助シーブを装着できる主ブーム長さは、15.2m（50）～61.0m（200）です。
- ジブを装着できる主ブーム長さは、24.4m（80）～61.0m（200）です。
- ▲ 操作ミスなどによるつり荷の落下を防ぐため、クレーン作業では自由降下（フリーフォール）作業は行わないでください。

● 巻上げロープ巻掛本数に対する最大巻上荷重とフックの質量

フック 呼称	最大巻上荷重 (t)										フック 質量
	1本掛	2本掛	3本掛	4本掛	5本掛	6本掛	7本掛	8本掛	9本掛	10本掛	
120t				48.0	60.0	72.0	84.0	96.0	108.0	120.0	1.70t
70t		24.0	36.0	48.0	60.0	70.0					1.20t
35t		24.0	35.0								0.90t
12.0t ボールフック	12.0										0.45t

主ブーム定格総荷重表

(単位:t)

ブーム長さ 作業半径 (m)	15.2	18.3	21.3	24.4	27.4	30.5	33.5	36.6	39.6	42.7	45.7	48.8	51.8	54.9	57.9	61.0	ブーム長さ 作業半径 (m)
4.5	120.0/4.5m																4.5
5.0	120.0	108.0/5.1m	96.0/5.6m														5.0
6.0	100.0	99.8	94.9	84.0/6.1m	74.6/6.7m												6.0
7.0	85.7	85.5	85.3	81.5	73.7	66.4/7.2m	59.4/7.7m										7.0
8.0	73.7	73.6	73.5	73.5	71.3	64.7	58.9	53.6/8.2m	48.0/8.8m								8.0
9.0	61.5	61.3	61.2	61.1	61.0	60.9	57.2	52.5	48.0	43.5/9.3m	39.6/9.8m						9.0
10.0	52.6	52.5	52.3	52.2	52.1	52.0	52.0	51.2	46.8	42.8	39.5	36.0/10.4m	32.1/10.9m	29.4/11.4m			10.0
12.0	40.6	40.5	40.3	40.2	40.0	40.0	39.9	39.7	39.7	39.5	37.8	34.7	31.4	29.0	26.9	24.0/12.5m	12.0
14.0	33.0	32.8	32.6	32.5	32.3	32.3	32.2	32.0	31.9	31.8	31.6	31.6	30.1	27.9	25.9	23.5	14.0
16.0	29.1/14.9m	27.5	27.3	27.2	26.9	26.9	26.8	26.6	26.5	26.4	26.2	26.1	26.0	25.8	24.9	22.8	16.0
18.0		24.5/17.5m	23.3	23.2	23.0	22.9	22.8	22.6	22.5	22.4	22.2	22.1	22.0	21.8	21.6	21.4	18.0
20.0			20.3	20.2	20.0	19.9	19.8	19.5	19.5	19.3	19.1	19.1	18.9	18.7	18.6	18.5	20.0
22.0			20.2/20.1m	17.8	17.6	17.5	17.4	17.1	17.1	16.9	16.7	16.6	16.5	16.3	16.1	16.0	22.0
24.0				17.1/22.8m	15.6	15.5	15.4	15.2	15.1	14.9	14.7	14.7	14.5	14.3	14.1	14.1	24.0
26.0					14.5/25.4m	13.9	13.8	13.6	13.5	13.3	13.1	13.0	12.9	12.7	12.5	12.4	26.0
28.0						12.6	12.5	12.2	12.1	12.0	11.7	11.7	11.5	11.3	11.1	11.0	28.0
30.0								11.3	11.1	11.0	10.8	10.6	10.5	10.3	10.1	10.0	30.0
32.0								11.0/30.7m	10.1	10.0	9.8	9.6	9.5	9.3	9.1	9.0	32.0
34.0									9.5/33.3m	9.1	8.9	8.7	8.6	8.5	8.2	8.1	34.0
36.0										8.4	8.2	8.0	7.9	7.7	7.5	7.3	36.0
38.0											7.5	7.3	7.2	7.0	6.8	6.6	38.0
40.0										7.4/38.6m	6.7	6.6	6.4	6.2	6.0	5.9	40.0
42.0												6.4/41.2m	6.1	5.9	5.7	5.5	42.0
44.0													5.6/43.9m	5.4	5.2	5.0	44.0
46.0														5.0	4.7	4.6	46.0
48.0													4.9/48.5m	4.3	4.1	3.9	48.0
50.0														4.1/49.2m	3.7	3.5	50.0
52.0															3.3/51.8m	3.1	52.0
54.0																2.7	54.0
56.0																2.7/54.4m	56.0

※表中の太線で囲まれた部分は、ブーム等の強度によって定められた値です。

補助シーブ定格総荷重表 (主ブームにフックなし)

(単位:t)

ブーム長さ 作業半径 (m)	15.2	18.3	21.3	24.4	27.4	30.5	33.5	36.6	39.6	42.7	45.7	48.8	51.8	54.9	57.9	61.0	ブーム長さ 作業半径 (m)
4.5																	4.5
5.0	12.0/5.3m	12.0/5.8m															5.0
6.0	12.0	12.0	12.0/6.3m	12.0/6.9m													6.0
7.0	12.0	12.0	12.0	12.0	12.0/7.4m	12.0/7.9m											7.0
8.0	12.0	12.0	12.0	12.0	12.0	12.0	12.0/8.4m										8.0
9.0	12.0	12.0	12.0	12.0	12.0	12.0	12.0	12.0/9.5m									9.0
10.0	12.0	12.0	12.0	12.0	12.0	12.0	12.0	12.0	12.0	12.0	12.0/10.6m	12.0/11.1m	12.0/11.6m				10.0
12.0	12.0	12.0	12.0	12.0	12.0	12.0	12.0	12.0	12.0	12.0	12.0	12.0	12.0	12.0/12.2m	12.0/12.7m	12.0/13.2m	12.0
14.0	12.0	12.0	12.0	12.0	12.0	12.0	12.0	12.0	12.0	12.0	12.0	12.0	12.0	12.0	12.0	12.0	14.0
16.0	12.0	12.0	12.0	12.0	12.0	12.0	12.0	12.0	12.0	12.0	12.0	12.0	12.0	12.0	12.0	12.0	16.0
18.0	12.0/16.2m	12.0	12.0	12.0	12.0	12.0	12.0	12.0	12.0	12.0	12.0	12.0	12.0	12.0	12.0	12.0	18.0
20.0		12.0/18.8m	12.0	12.0	12.0	12.0	12.0	12.0	12.0	12.0	12.0	12.0	12.0	12.0	12.0	12.0	20.0
22.0			12.0/21.5m	12.0	12.0	12.0	12.0	12.0	12.0	12.0	12.0	12.0	12.0	12.0	12.0	12.0	22.0
24.0				12.0	12.0	12.0	12.0	12.0	12.0	12.0	12.0	12.0	12.0	12.0	12.0	12.0	24.0
26.0				12.0/24.1m	12.0	12.0	12.0	12.0	12.0	12.0	12.0	12.0	12.0	12.0	12.0	12.0	26.0
28.0					12.0/26.7m	12.0	12.0	11.9	11.8	11.7	11.4	11.4	11.2	11.0	10.8	10.7	28.0
30.0						12.0/29.4m	11.0	10.8	10.7	10.5	10.3	10.2	10.0	9.8	9.7	9.6	30.0
32.0							10.1	9.8	9.7	9.5	9.3	9.2	9.0	8.8	8.7	8.6	32.0
34.0								8.9	8.8	8.6	8.4	8.3	8.2	7.9	7.8	7.7	34.0
36.0								8.6/34.7m	8.1	7.9	7.7	7.6	7.4	7.2	7.0	6.9	36.0
38.0									7.6/37.3m	7.2	7.0	6.9	6.7	6.5	6.3	6.2	38.0
40.0										6.9/39.9m	6.4	6.3	6.1	5.9	5.7	5.6	40.0
42.0											5.9	5.8	5.6	5.4	5.2	5.1	42.0
44.0											5.8/42.6m	5.3	5.1	4.9	4.7	4.6	44.0
46.0												5.0/45.2m	4.7	4.4	4.3	4.1	46.0
48.0													4.3/47.9m	4.0	3.8	3.6	48.0
50.0														3.7	3.4	3.2	50.0
52.0														3.6/50.5m	3.0	2.8	52.0
54.0															2.7/53.1m	2.4	54.0
56.0																2.0/55.8m	56.0

※表中の太線で囲まれた部分は、ブーム等の強度によって定められた値です。

▶ ロング主ブーム定格総荷重表

(単位:t)

ブーム長さ 作業半径 (m)	61.0	64.0	67.1	70.1	73.2	76.2	79.2	ブーム長さ 作業半径 (m)
12.0	24.0/12.3m	24.0/12.8m	24.0/13.3m	24.0/13.9m				12.0
14.0	24.0	24.0	24.0	24.0	22.1/14.4m	18.7/14.9m	16.3/15.4m	14.0
16.0	24.0	24.0	24.0	24.0	20.9	17.9	15.9	16.0
18.0	22.8	22.6	22.5	22.5	19.5	16.7	14.8	18.0
20.0	19.7	19.5	19.5	19.4	18.3	15.7	13.9	20.0
22.0	17.3	17.1	17.0	17.0	16.9	14.8	13.1	22.0
24.0	15.3	15.1	15.0	15.0	14.9	14.0	12.3	24.0
26.0	13.7	13.5	13.4	13.4	13.3	13.1	11.7	26.0
28.0	12.3	12.1	12.0	12.0	11.9	11.7	11.2	28.0
30.0	11.1	10.9	10.8	10.8	10.7	10.6	10.5	30.0
32.0	10.1	9.9	9.8	9.8	9.7	9.5	9.5	32.0
34.0	9.2	9.0	8.9	8.9	8.8	8.7	8.6	34.0
36.0	8.4	8.3	8.2	8.1	8.0	7.9	7.8	36.0
38.0	7.8	7.6	7.5	7.5	7.4	7.2	7.2	38.0
40.0	7.2	7.0	6.9	6.8	6.7	6.6	6.5	40.0
42.0	6.6	6.4	6.3	6.3	6.2	6.0	6.0	42.0
44.0	6.1	5.9	5.8	5.8	5.7	5.5	5.5	44.0
46.0	5.7	5.5	5.4	5.3	5.2	5.1	5.0	46.0
48.0	5.3	5.1	5.0	4.9	4.8	4.7	4.6	48.0
50.0	4.9	4.7	4.6	4.6	4.5	4.3	4.3	50.0
52.0	4.6	4.4	4.3	4.2	4.1	4.0	3.9	52.0
54.0	4.3	4.1	3.9	3.9	3.8	3.6	3.5	54.0
56.0	4.2/54.4m	3.8	3.7	3.6	3.5	3.3	3.2	56.0
58.0		3.6/57.0m	3.4	3.3	3.2	2.9	2.9	58.0
60.0			3.1/59.7m	3.0	2.9	2.6	2.6	60.0
62.0				2.8	2.6	2.4	2.3	62.0
64.0				2.7/62.3m	2.4	2.1	2.0	64.0
66.0					2.2/64.9m			66.0

※表中の太線で囲まれた部分は、ブーム等の強度によって定められた値です。

▶ ロング補助シーブ定格総荷重表 (主ブームにフックなし)

(単位:t)

ブーム長さ 作業半径 (m)	61.0	64.0	67.1	70.1	73.2	76.2	ブーム長さ 作業半径 (m)
12.0	12.0/12.9m	12.0/13.4m					12.0
14.0	12.0	12.0	12.0	12.0/14.5m	12.0/15.0m	12.0/15.5m	14.0
16.0	12.0	12.0	12.0	12.0	12.0	12.0	16.0
18.0	12.0	12.0	12.0	12.0	12.0	12.0	18.0
20.0	12.0	12.0	12.0	12.0	12.0	12.0	20.0
22.0	12.0	12.0	12.0	12.0	12.0	12.0	22.0
24.0	12.0	12.0	12.0	12.0	12.0	12.0	24.0
26.0	12.0	12.0	12.0	12.0	12.0	12.0	26.0
28.0	12.0	11.8	11.7	11.7	11.6	11.4	28.0
30.0	10.8	10.6	10.5	10.5	10.4	10.3	30.0
32.0	9.8	9.6	9.5	9.5	9.4	9.2	32.0
34.0	8.9	8.7	8.6	8.6	8.5	8.4	34.0
36.0	8.1	8.0	7.9	7.8	7.7	7.6	36.0
38.0	7.5	7.3	7.2	7.2	7.1	6.9	38.0
40.0	6.9	6.7	6.6	6.5	6.4	6.3	40.0
42.0	6.3	6.1	6.0	6.0	5.9	5.7	42.0
44.0	5.8	5.6	5.5	5.5	5.4	5.2	44.0
46.0	5.4	5.2	5.1	5.0	4.9	4.8	46.0
48.0	5.0	4.8	4.7	4.6	4.5	4.4	48.0
50.0	4.6	4.4	4.3	4.3	4.2	4.0	50.0
52.0	4.3	4.1	4.0	3.9	3.8	3.7	52.0
54.0	4.0	3.8	3.6	3.6	3.5	3.3	54.0
56.0	3.7/55.1m	3.5	3.4	3.3	3.2	3.0	56.0
58.0		3.2/57.8m	3.1	3.0	2.9	2.6	58.0
60.0			2.8	2.7	2.6	2.3	60.0
62.0			2.7/60.4m	2.5	2.3	2.1	62.0
64.0				2.4/63.0m	2.1		64.0
66.0							66.0

※表中の太線で囲まれた部分は、ブーム等の強度によって定められた値です。

ジブ定格総荷重表(主フックなし/ジブオフセット角度10°)

(単位:t)

ブーム長さ(m) ジブ長さ(m) 作業半径(m)	24.4				27.4				30.5				33.5				ブーム長さ(m) ジブ長さ(m) 作業半径(m)
	12.2	18.3	24.4	30.5	12.2	18.3	24.4	30.5	12.2	18.3	24.4	30.5	12.2	18.3	24.4	30.5	
10.0	12.0/10.2m				12.0/10.7m				12.0/11.2m				12.0/11.7m				10.0
12.0	12.0	12.0/12.2m			12.0	12.0/12.8m			12.0	12.0/13.3m			12.0	12.0/13.8m			12.0
14.0	12.0	12.0	8.0/14.3m		12.0	12.0	8.0/14.9m		12.0	12.0	8.0/15.4m		12.0	12.0	8.0/15.9m		14.0
16.0	12.0	12.0	8.0	4.0/16.4m	12.0	12.0	8.0	4.0/16.9m	12.0	12.0	8.0	4.0/17.5m	12.0	12.0	8.0		16.0
18.0	12.0	12.0	8.0	4.0	12.0	12.0	8.0	4.0	12.0	12.0	8.0	4.0	12.0	12.0	8.0	4.0	18.0
20.0	12.0	12.0	8.0	4.0	12.0	12.0	8.0	4.0	12.0	12.0	8.0	4.0	12.0	12.0	8.0	4.0	20.0
22.0	12.0	12.0	7.6	4.0	12.0	12.0	7.8	4.0	12.0	12.0	8.0	4.0	12.0	12.0	8.0	4.0	22.0
24.0	12.0	12.0	7.3	4.0	12.0	12.0	7.4	4.0	12.0	12.0	7.6	4.0	12.0	12.0	7.8	4.0	24.0
26.0	12.0	12.0	7.0	4.0	12.0	12.0	7.1	4.0	12.0	12.0	7.3	4.0	12.0	12.0	7.5	4.0	26.0
28.0	12.0	11.8	6.7	3.9	12.0	12.0	6.9	4.0	12.0	12.0	7.0	4.0	12.0	12.0	7.2	4.0	28.0
30.0	12.0	11.0	6.4	3.7	11.8	11.7	6.6	3.8	11.7	11.9	6.8	3.9	11.5	11.7	6.9	4.0	30.0
32.0	11.1	10.3	6.2	3.5	10.8	11.0	6.4	3.6	10.6	10.9	6.5	3.7	10.5	10.7	6.7	3.8	32.0
34.0	10.2	9.7	6.0	3.4	9.9	10.1	6.2	3.5	9.8	10.0	6.3	3.6	9.6	9.8	6.5	3.7	34.0
36.0		9.2	5.8	3.2	9.2	9.4	6.0	3.3	9.0	9.2	6.1	3.4	8.8	9.0	6.3	3.5	36.0
38.0		8.7	5.6	3.1		8.7	5.8	3.2	8.3	8.5	5.9	3.3	8.1	8.3	6.1	3.4	38.0
40.0		8.3	5.5	3.0		8.1	5.6	3.1	7.7	7.9	5.8	3.2	7.5	7.7	5.9	3.3	40.0
42.0			5.3	2.9		7.5	5.5	3.0		7.3	5.6	3.1	7.0	7.2	5.8	3.2	42.0
44.0			5.2	2.8			5.4	2.9		6.9	5.5	3.0		6.7	5.6	3.1	44.0
46.0				2.7			5.2	2.8			5.4	2.9		6.2	5.5	3.0	46.0
48.0				2.6			5.2	2.7			5.3	2.8		5.8	5.4	2.9	48.0
50.0				2.6				2.6			5.2	2.7			5.3	2.8	50.0
52.0								2.6				2.6			5.2	2.7	52.0
54.0												2.6				2.7	54.0
56.0												2.5				2.6	56.0
58.0																2.5	58.0

※表中の太線で囲まれた部分は、ブーム等の強度によって定められた値です。

ブーム長さ(m) ジブ長さ(m) 作業半径(m)	36.6				39.6				42.7				ブーム長さ(m) ジブ長さ(m) 作業半径(m)
	12.2	18.3	24.4	30.5	12.2	18.3	24.4	30.5	12.2	18.3	24.4	30.5	
12.0	12.0/12.3m				12.0/12.8m				12.0/13.3m				12.0
14.0	12.0	12.0/14.4m			12.0	12.0/14.9m			12.0	12.0/15.4m			14.0
16.0	12.0	12.0	8.0/16.4m		12.0	12.0	8.0/17.0m		12.0	12.0	8.0/17.5m		16.0
18.0	12.0	12.0	8.0	4.0/18.5m	12.0	12.0	8.0	4.0/19.1m	12.0	12.0	8.0	4.0/19.6m	18.0
20.0	12.0	12.0	8.0	4.0	12.0	12.0	8.0	4.0	12.0	12.0	8.0	4.0	20.0
22.0	12.0	12.0	8.0	4.0	12.0	12.0	8.0	4.0	12.0	12.0	8.0	4.0	22.0
24.0	12.0	12.0	7.9	4.0	12.0	12.0	8.0	4.0	12.0	12.0	8.0	4.0	24.0
26.0	12.0	12.0	7.6	4.0	12.0	12.0	7.8	4.0	12.0	12.0	7.9	4.0	26.0
28.0	12.0	12.0	7.3	4.0	12.0	12.0	7.5	4.0	12.0	12.0	7.6	4.0	28.0
30.0	11.3	11.5	7.1	4.0	11.1	11.4	7.2	4.0	11.0	11.2	7.4	4.0	30.0
32.0	10.3	10.5	6.9	3.9	10.1	10.3	7.0	4.0	9.9	10.2	7.1	4.0	32.0
34.0	9.4	9.6	6.6	3.8	9.2	9.4	6.8	3.9	9.0	9.3	6.9	4.0	34.0
36.0	8.6	8.8	6.4	3.6	8.4	8.7	6.6	3.7	8.3	8.5	6.7	3.8	36.0
38.0	7.9	8.1	6.2	3.5	7.8	8.0	6.4	3.6	7.6	7.8	6.5	3.7	38.0
40.0	7.3	7.5	6.1	3.4	7.1	7.3	6.2	3.5	7.0	7.2	6.3	3.6	40.0
42.0	6.8	6.9	5.9	3.3	6.6	6.8	6.0	3.4	6.4	6.6	6.2	3.4	42.0
44.0	6.3	6.4	5.8	3.2	6.1	6.3	5.9	3.2	5.9	6.1	6.0	3.3	44.0
46.0		6.0	5.6	3.1	5.7	5.8	5.8	3.1	5.5	5.7	5.9	3.2	46.0
48.0		5.6	5.5	3.0		5.4	5.6	3.0	5.1	5.2	5.5	3.1	48.0
50.0		5.2	5.4	2.9		5.1	5.3	3.0	4.7	4.9	5.1	3.0	50.0
52.0			5.1	2.8		4.7	4.9	2.9		4.5	4.8	3.0	52.0
54.0			4.7	2.7			4.6	2.8		4.2	4.4	2.9	54.0
56.0			4.5	2.7			4.3	2.7		3.9	4.1	2.8	56.0
58.0				2.6			4.0	2.7			3.9	2.7	58.0
60.0				2.5				2.6			3.6	2.7	60.0
62.0								2.6				2.6	62.0
64.0								2.5				2.6	64.0
66.0												2.5	66.0

※表中の太線で囲まれた部分は、ブーム等の強度によって定められた値です。

ブーム長さ(m) ジブ長さ(m) 作業半径(m)	45.7				48.8				51.8				ブーム長さ(m) ジブ長さ(m) 作業半径(m)
	12.2	18.3	24.4	30.5	12.2	18.3	24.4	30.5	12.2	18.3	24.4	30.5	
12.0	12.0/13.9m												12.0
14.0	12.0	12.0/15.9m			12.0/14.4m				12.0/14.9m				14.0
16.0	12.0	12.0			12.0	12.0/16.5m			12.0	12.0/17.0m			16.0
18.0	12.0	12.0	8.0		12.0	12.0	8.0/18.6m		12.0	12.0	8.0/19.1m		18.0
20.0	12.0	12.0	8.0	4.0/20.1m	12.0	12.0	8.0	4.0/20.6m	12.0	12.0	8.0	4.0/21.2m	20.0
22.0	12.0	12.0	8.0	4.0	12.0	12.0	8.0	4.0	12.0	12.0	8.0	4.0	22.0
24.0	12.0	12.0	8.0	4.0	12.0	12.0	8.0	4.0	12.0	12.0	8.0	4.0	24.0
26.0	12.0	12.0	8.0	4.0	12.0	12.0	8.0	4.0	12.0	12.0	8.0	4.0	26.0
28.0	11.9	12.0	7.8	4.0	11.8	12.0	7.9	4.0	11.6	11.9	8.0	4.0	28.0
30.0	10.7	11.0	7.5	4.0	10.6	10.9	7.6	4.0	10.4	10.7	7.8	4.0	30.0
32.0	9.7	10.0	7.3	4.0	9.6	9.8	7.4	4.0	9.4	9.7	7.5	4.0	32.0
34.0	8.8	9.1	7.1	4.0	8.7	8.9	7.2	4.0	8.5	8.8	7.3	4.0	34.0
36.0	8.0	8.3	6.8	3.9	7.9	8.1	7.0	4.0	7.7	8.0	7.1	4.0	36.0
38.0	7.3	7.6	6.7	3.8	7.2	7.4	6.8	3.8	7.0	7.3	6.9	3.9	38.0
40.0	6.7	7.0	6.5	3.6	6.6	6.8	6.6	3.7	6.4	6.6	6.7	3.8	40.0
42.0	6.2	6.4	6.3	3.5	6.0	6.2	6.4	3.6	5.9	6.1	6.4	3.7	42.0
44.0	5.7	5.9	6.2	3.4	5.5	5.7	6.0	3.5	5.4	5.6	5.9	3.6	44.0
46.0	5.2	5.4	5.7	3.3	5.1	5.3	5.6	3.4	4.9	5.1	5.4	3.4	46.0
48.0	4.8	5.0	5.3	3.2	4.7	4.9	5.1	3.3	4.5	4.7	5.0	3.4	48.0
50.0	4.5	4.6	4.9	3.1	4.3	4.5	4.8	3.2	4.1	4.3	4.6	3.3	50.0
52.0	4.1	4.3	4.5	3.0	4.0	4.1	4.4	3.1	3.7	4.0	4.2	3.2	52.0
54.0		4.0	4.2	2.9	3.6	3.8	4.1	3.0	3.4	3.6	3.9	3.1	54.0
56.0		3.7	3.9	2.9		3.5	3.8	2.9	3.0	3.3	3.6	3.0	56.0
58.0		3.4	3.6	2.8		3.2	3.5	2.9	2.7	2.9	3.3	2.9	58.0
60.0			3.4	2.7		2.9	3.2	2.8		2.6	3.0	2.9	60.0
62.0			3.1	2.7			2.9	2.7		2.4	2.7	2.8	62.0
64.0			2.9	2.6			2.6	2.7			2.4	2.5	64.0
66.0				2.6			2.4	2.5			2.2	2.3	66.0
68.0				2.5				2.3				2.0	68.0
70.0								2.1					70.0

※表中の太線で囲まれた部分は、ブーム等の強度によって定められた値です。

ブーム長さ(m) ジブ長さ(m) 作業半径(m)	54.9				57.9				61.0				ブーム長さ(m) ジブ長さ(m) 作業半径(m)
	12.2	18.3	24.4	30.5	12.2	18.3	24.4	30.5	12.2	18.3	24.4	30.5	
14.0	12.0/15.4m												14.0
16.0	12.0	12.0/17.5m			12.0				12.0/16.5m				16.0
18.0	12.0	12.0	8.0/19.6m		12.0	12.0/18.1m			12.0	12.0/18.6m			18.0
20.0	12.0	12.0	8.0	4.0/21.7m	12.0	12.0	8.0/20.1m		12.0	12.0	8.0/20.7m		20.0
22.0	12.0	12.0	8.0	4.0	12.0	12.0	8.0	4.0/22.2m	12.0	12.0	8.0	4.0/22.8m	22.0
24.0	12.0	12.0	8.0	4.0	12.0	12.0	8.0	4.0	12.0	12.0	8.0	4.0	24.0
26.0	12.0	12.0	8.0	4.0	12.0	12.0	8.0	4.0	12.0	12.0	8.0	4.0	26.0
28.0	11.4	11.7	8.0	4.0	11.2	11.5	8.0	4.0	11.1	11.4	8.0	4.0	28.0
30.0	10.2	10.5	7.9	4.0	10.0	10.3	8.0	4.0	9.9	10.2	8.0	4.0	30.0
32.0	9.2	9.5	7.6	4.0	9.0	9.3	7.7	4.0	8.9	9.1	7.8	4.0	32.0
34.0	8.3	8.6	7.4	4.0	8.1	8.4	7.5	4.0	8.0	8.2	7.6	4.0	34.0
36.0	7.5	7.8	7.2	4.0	7.3	7.6	7.3	4.0	7.2	7.4	7.4	4.0	36.0
38.0	6.8	7.1	7.0	4.0	6.6	6.9	7.1	4.0	6.5	6.7	7.1	4.0	38.0
40.0	6.2	6.4	6.8	3.9	6.0	6.2	6.6	3.9	5.8	6.1	6.4	4.0	40.0
42.0	5.6	5.9	6.2	3.7	5.5	5.7	6.0	3.8	5.3	5.5	5.9	3.9	42.0
44.0	5.1	5.4	5.7	3.6	4.9	5.2	5.5	3.7	4.8	5.0	5.4	3.8	44.0
46.0	4.7	4.9	5.2	3.5	4.5	4.7	5.0	3.6	4.3	4.5	4.9	3.7	46.0
48.0	4.3	4.5	4.8	3.4	4.0	4.3	4.6	3.5	3.8	4.1	4.5	3.6	48.0
50.0	3.8	4.1	4.4	3.3	3.6	3.9	4.2	3.4	3.3	3.6	4.1	3.5	50.0
52.0	3.4	3.7	4.0	3.2	3.2	3.4	3.9	3.3	2.9	3.2	3.6	3.4	52.0
54.0	3.0	3.3	3.7	3.2	2.8	3.1	3.5	3.2	2.5	2.8	3.2	3.3	54.0
56.0	2.7	3.0	3.3	3.1	2.4	2.7	3.1	3.1	2.2	2.5	2.9	3.0	56.0
58.0	2.4	2.6	3.0	3.0	2.1	2.4	2.8	2.9		2.1	2.5	2.7	58.0
60.0		2.3	2.7	2.8		2.1	2.4	2.6			2.2	2.4	60.0
62.0		2.1	2.4	2.5			2.2	2.3				2.1	62.0
64.0			2.1	2.3				2.0					64.0
66.0				2.0									66.0

※表中の太線で囲まれた部分は、ブーム等の強度によって定められた値です。

ジブ定格総荷重表 (主フックなし/ジブオフセット角度30°)

(単位:t)

ブーム長さ(m) ジブ長さ(m) 作業半径(m)	24.4				27.4				30.5				33.5				ブーム長さ(m) ジブ長さ(m) 作業半径(m)
	12.2	18.3	24.4	30.5	12.2	18.3	24.4	30.5	12.2	18.3	24.4	30.5	12.2	18.3	24.4	30.5	
12.0	10.0/13.8m																12.0
14.0	10.0				10.0/14.3m				10.0/14.9m				10.0/15.4m				14.0
16.0	10.0	9.0/17.7m			10.0				10.0				10.0				16.0
18.0	10.0	9.0			10.0	9.0/18.3m			10.0	9.0/18.8m			10.0	9.0/19.3m			18.0
20.0	10.0	9.0	6.0/21.7m		10.0	9.0			10.0	9.0			10.0	9.0			20.0
22.0	10.0	9.0	6.0		10.0	9.0	6.0/22.2m		10.0	9.0	6.0/22.7m		10.0	9.0	6.0/23.2m		22.0
24.0	10.0	9.0	6.0	3.0/25.6m	10.0	9.0	6.0		10.0	9.0	6.0		10.0	9.0	6.0		24.0
26.0	10.0	9.0	6.0	3.0	10.0	9.0	6.0	3.0/26.1m	10.0	9.0	6.0	3.0/26.6m	10.0	9.0	6.0	3.0/27.2m	26.0
28.0	10.0	8.7	5.8	3.0	10.0	9.0	5.9	3.0	10.0	9.0	6.0	3.0	10.0	9.0	6.0	3.0	28.0
30.0	10.0	8.3	5.7	3.0	10.0	8.6	5.8	3.0	10.0	8.9	5.8	3.0	10.0	9.0	5.9	3.0	30.0
32.0	10.0	7.9	5.5	3.0	10.0	8.2	5.6	3.0	10.0	8.5	5.7	3.0	10.0	8.7	5.8	3.0	32.0
34.0	10.0	7.6	5.4	2.9	10.0	7.9	5.5	3.0	9.9	8.1	5.6	3.0	9.8	8.4	5.6	3.0	34.0
36.0		7.3	5.3	2.8	9.3	7.6	5.4	2.9	9.1	7.8	5.5	2.9	9.0	8.1	5.5	3.0	36.0
38.0		7.1	5.2	2.7		7.3	5.3	2.8	8.4	7.5	5.4	2.8	8.3	7.8	5.4	2.9	38.0
40.0		6.9	5.1	2.7		7.1	5.2	2.7	7.8	7.3	5.3	2.8	7.6	7.5	5.3	2.8	40.0
42.0			5.0	2.6		6.9	5.1	2.7		7.1	5.2	2.7	7.1	7.3	5.2	2.7	42.0
44.0			4.8	2.6			5.0	2.6		7.0	5.1	2.6		6.9	5.2	2.7	44.0
46.0			4.7	2.5			4.8	2.5		6.5	5.0	2.6		6.4	5.1	2.6	46.0
48.0				2.5			4.7	2.5			4.8	2.5		6.0	5.0	2.6	48.0
50.0				2.4				2.5			4.8	2.5			4.9	2.5	50.0
52.0				2.4				2.4			4.7	2.5			4.8	2.5	52.0
54.0								2.4				2.4			4.7	2.5	54.0
56.0												2.4				2.4	56.0
58.0												2.4				2.4	58.0
60.0																2.4	60.0

※表中の太線で囲まれた部分は、ブーム等の強度によって定められた値です。

ブーム長さ(m) ジブ長さ(m) 作業半径(m)	36.6				39.6				42.7				ブーム長さ(m) ジブ長さ(m) 作業半径(m)
	12.2	18.3	24.4	30.5	12.2	18.3	24.4	30.5	12.2	18.3	24.4	30.5	
14.0	10.0/15.9m												14.0
16.0	10.0				10.0/16.5m				10.0/17.0m				16.0
18.0	10.0	9.0/19.9m			10.0				10.0				18.0
20.0	10.0	9.0			10.0	9.0/20.4m			10.0	9.0/20.9m			20.0
22.0	10.0	9.0	6.0/23.8m		10.0	9.0			10.0	9.0			22.0
24.0	10.0	9.0	6.0	3.0/27.7m	10.0	9.0	6.0/24.3m		10.0	9.0	6.0/24.8m		24.0
26.0	10.0	9.0	6.0	3.0	10.0	9.0	6.0	3.0/28.2m	10.0	9.0	6.0	3.0/28.8m	26.0
28.0	10.0	9.0	6.0	3.0	10.0	9.0	6.0	3.0	10.0	9.0	6.0	3.0	28.0
30.0	10.0	9.0	6.0	3.0	10.0	9.0	6.0	3.0	10.0	9.0	6.0	3.0	30.0
32.0	10.0	9.0	5.8	3.0	10.0	9.0	5.9	3.0	10.0	9.0	5.9	3.0	32.0
34.0	9.6	8.6	5.7	3.0	9.5	8.9	5.8	3.0	9.3	9.0	5.8	3.0	34.0
36.0	8.8	8.3	5.6	3.0	8.7	8.5	5.6	3.0	8.5	8.7	5.7	3.0	36.0
38.0	8.1	8.0	5.5	2.9	7.9	8.2	5.5	3.0	7.8	8.3	5.6	3.0	38.0
40.0	7.4	7.8	5.4	2.8	7.3	7.7	5.4	2.9	7.1	7.6	5.5	2.9	40.0
42.0	6.9	7.3	5.3	2.8	6.7	7.1	5.4	2.8	6.6	7.0	5.4	2.8	42.0
44.0	6.3	6.7	5.2	2.7	6.2	6.6	5.3	2.7	6.1	6.5	5.3	2.8	44.0
46.0		6.2	5.2	2.7	5.7	6.1	5.2	2.7	5.6	6.0	5.3	2.7	46.0
48.0		5.8	5.1	2.6	5.3	5.7	5.2	2.6	5.1	5.5	5.2	2.7	48.0
50.0		5.4	5.0	2.6		5.3	5.1	2.6	4.8	5.1	5.1	2.6	50.0
52.0		5.0	4.9	2.5		4.9	5.0	2.5		4.7	5.0	2.6	52.0
54.0			4.8	2.5		4.5	4.8	2.5		4.4	4.6	2.5	54.0
56.0			4.6	2.5			4.5	2.5		4.1	4.3	2.5	56.0
58.0				2.4			4.1	2.5			4.0	2.5	58.0
60.0				2.4			3.9	2.4			3.7	2.4	60.0
62.0				2.4				2.4			3.5	2.4	62.0
64.0								2.4				2.4	64.0
66.0								2.4				2.4	66.0

※表中の太線で囲まれた部分は、ブーム等の強度によって定められた値です。

ブーム長さ (m) ジブ長さ (m) 作業半径 (m)	45.7				48.8				51.8				ブーム長さ (m) ジブ長さ (m) 作業半径 (m)
	12.2	18.3	24.4	30.5	12.2	18.3	24.4	30.5	12.2	18.3	24.4	30.5	
16.0	10.0/17.5m												16.0
18.0	10.0				10.0/18.1m				10.0/18.6m				18.0
20.0	10.0	9.0/21.4m			10.0				10.0				20.0
22.0	10.0	9.0			10.0	9.0			10.0	9.0/22.5m			22.0
24.0	10.0	9.0	6.0/25.4m		10.0	9.0	6.0/25.9m		10.0	9.0			24.0
26.0	10.0	9.0	6.0		10.0	9.0	6.0		10.0	9.0	6.0/26.4m		26.0
28.0	10.0	9.0	6.0	3.0/29.3m	10.0	9.0	6.0	3.0/29.8m	10.0	9.0	6.0		28.0
30.0	10.0	9.0	6.0	3.0	10.0	9.0	6.0	3.0	10.0	9.0	6.0	3.0/30.3m	30.0
32.0	10.0	9.0	6.0	3.0	10.0	9.0	6.0	3.0	9.8	9.0	6.0	3.0	32.0
34.0	9.1	9.0	5.9	3.0	9.0	9.0	5.9	3.0	8.9	9.0	6.0	3.0	34.0
36.0	8.3	8.8	5.8	3.0	8.2	8.7	5.8	3.0	8.1	8.6	5.9	3.0	36.0
38.0	7.6	8.1	5.7	3.0	7.5	8.0	5.7	3.0	7.3	7.9	5.8	3.0	38.0
40.0	7.0	7.4	5.6	2.9	6.8	7.3	5.6	3.0	6.7	7.2	5.7	3.0	40.0
42.0	6.4	6.8	5.5	2.9	6.2	6.7	5.5	2.9	6.1	6.6	5.6	2.9	42.0
44.0	5.8	6.3	5.4	2.8	5.7	6.2	5.4	2.8	5.6	6.0	5.5	2.9	44.0
46.0	5.4	5.8	5.3	2.8	5.2	5.7	5.4	2.8	5.1	5.5	5.4	2.8	46.0
48.0	4.9	5.3	5.2	2.7	4.8	5.2	5.3	2.7	4.7	5.1	5.3	2.8	48.0
50.0	4.6	4.9	5.2	2.7	4.4	4.8	5.1	2.7	4.3	4.7	5.0	2.7	50.0
52.0	4.2	4.6	4.8	2.6	4.1	4.4	4.7	2.6	3.9	4.3	4.6	2.7	52.0
54.0		4.2	4.5	2.6	3.7	4.1	4.4	2.6	3.5	4.0	4.2	2.6	54.0
56.0		3.9	4.1	2.5	3.4	3.8	4.0	2.6	3.1	3.6	3.9	2.6	56.0
58.0		3.6	3.8	2.5		3.5	3.7	2.5	2.8	3.3	3.6	2.5	58.0
60.0		3.3	3.6	2.5		3.1	3.4	2.5		2.9	3.3	2.5	60.0
62.0			3.3	2.4		2.8	3.2	2.5		2.6	3.0	2.5	62.0
64.0				2.4			2.8	2.4		2.3	2.7	2.5	64.0
66.0				2.4			2.6	2.4			2.4	2.4	66.0
68.0				2.4			2.3	2.4			2.1	2.4	68.0
70.0				2.4				2.3				2.1	70.0
72.0								2.1					72.0

※表中の太線で囲まれた部分は、ブーム等の強度によって定められた値です。

ブーム長さ (m) ジブ長さ (m) 作業半径 (m)	54.9				57.9				61.0				ブーム長さ (m) ジブ長さ (m) 作業半径 (m)
	12.2	18.3	24.4	30.5	12.2	18.3	24.4	30.5	12.2	18.3	24.4	30.5	
18.0	10.0/19.1m				10.0/19.6m								18.0
20.0	10.0				10.0				10.0/20.1m				20.0
22.0	10.0	9.0/23.0m			10.0	9.0/23.6m			10.0				22.0
24.0	10.0	9.0			10.0	9.0			10.0	9.0/24.1m			24.0
26.0	10.0	9.0	6.0/26.9m		10.0	9.0	6.0/27.5m		10.0	9.0			26.0
28.0	10.0	9.0	6.0		10.0	9.0	6.0		10.0	9.0	6.0		28.0
30.0	10.0	9.0	6.0	3.0/30.9m	10.0	9.0	6.0	3.0/31.4m	10.0	9.0	6.0	3.0/31.9m	30.0
32.0	9.6	9.0	6.0	3.0	9.5	9.0	6.0	3.0	9.3	9.0	6.0	3.0	32.0
34.0	8.7	9.0	6.0	3.0	8.5	9.0	6.0	3.0	8.4	9.0	6.0	3.0	34.0
36.0	7.9	8.5	5.9	3.0	7.7	8.3	5.9	3.0	7.6	8.2	6.0	3.0	36.0
38.0	7.1	7.7	5.8	3.0	7.0	7.6	5.8	3.0	6.8	7.4	5.9	3.0	38.0
40.0	6.5	7.0	5.7	3.0	6.3	6.9	5.7	3.0	6.2	6.8	5.8	3.0	40.0
42.0	5.9	6.4	5.6	3.0	5.7	6.3	5.7	3.0	5.6	6.1	5.7	3.0	42.0
44.0	5.4	5.9	5.5	2.9	5.2	5.7	5.6	2.9	5.1	5.6	5.6	3.0	44.0
46.0	4.9	5.4	5.5	2.8	4.7	5.2	5.5	2.9	4.6	5.1	5.5	2.9	46.0
48.0	4.5	4.9	5.2	2.8	4.3	4.8	5.1	2.8	4.1	4.6	5.0	2.8	48.0
50.0	4.1	4.5	4.8	2.7	3.8	4.4	4.7	2.8	3.6	4.2	4.6	2.8	50.0
52.0	3.6	4.1	4.4	2.7	3.4	4.0	4.3	2.7	3.2	3.8	4.2	2.7	52.0
54.0	3.2	3.8	4.1	2.6	3.0	3.6	3.9	2.7	2.8	3.4	3.8	2.7	54.0
56.0	2.8	3.4	3.7	2.6	2.6	3.2	3.6	2.6	2.4	3.0	3.4	2.7	56.0
58.0	2.5	3.0	3.4	2.6	2.3	2.8	3.2	2.6	2.0	2.6	3.0	2.6	58.0
60.0	2.2	2.7	3.1	2.5	2.0	2.5	2.9	2.6		2.3	2.7	2.6	60.0
62.0		2.4	2.7	2.5		2.2	2.5	2.5		2.0	2.3	2.5	62.0
64.0		2.1	2.4	2.5			2.2	2.5			2.0	2.3	64.0
66.0			2.1	2.4				2.2				2.0	66.0
68.0				2.1									68.0

※表中の太線で囲まれた部分は、ブーム等の強度によって定められた値です。

ラッピングタワー

▶全体図 (単位: mm)

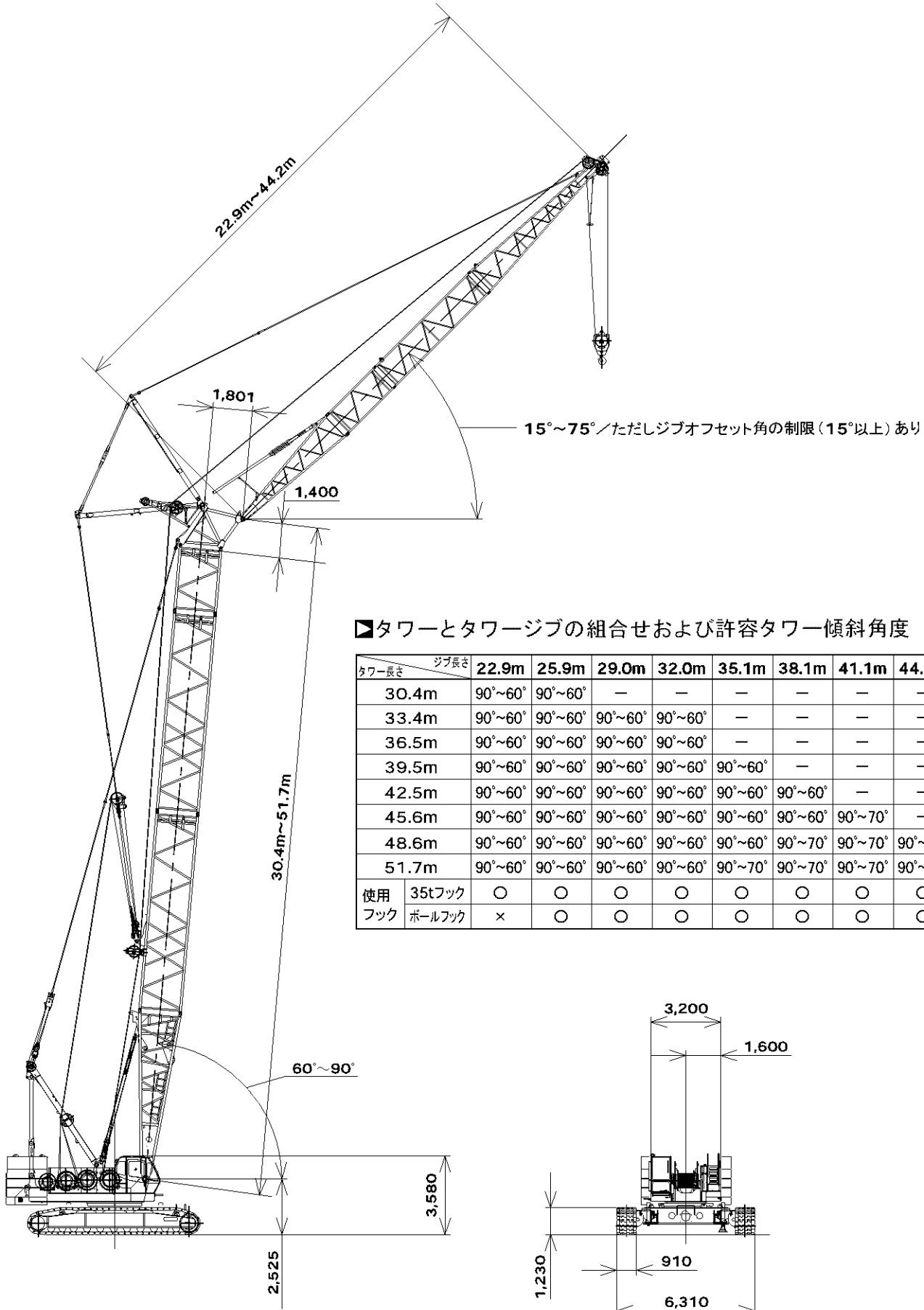

▶タワーとタワージブの組合せおよび許容タワー傾斜角度

タワー長さ	ジブ長さ									敷板
	22.9m	25.9m	29.0m	32.0m	35.1m	38.1m	41.1m	44.2m		
30.4m	90°~60°	90°~60°	—	—	—	—	—	—	—	—
33.4m	90°~60°	90°~60°	90°~60°	90°~60°	—	—	—	—	—	—
36.5m	90°~60°	90°~60°	90°~60°	90°~60°	—	—	—	—	—	—
39.5m	90°~60°	90°~60°	90°~60°	90°~60°	90°~60°	—	—	—	—	—
42.5m	90°~60°	90°~60°	90°~60°	90°~60°	90°~60°	90°~60°	—	—	—	—
45.6m	90°~60°	90°~60°	90°~60°	90°~60°	90°~60°	90°~60°	90°~70°	—	—	—
48.6m	90°~60°	90°~60°	90°~60°	90°~60°	90°~60°	90°~70°	90°~70°	90°~70°	90°~70°	—
51.7m	90°~60°	90°~60°	90°~60°	90°~60°	90°~70°	90°~70°	90°~70°	90°~70°	90°~70°	○
使用フック	35tフック	○	○	○	○	○	○	○	○	—
	ボールフック	×	○	○	○	○	○	○	○	—

■タワー構成

- ※印は、これより短いタワーの組立可能な構成を示します。
- 9.1Aは、クローラクレーンの中間ブームとしても使用できます。
- 下部ブーム直近の9.1m中間ブームには、9.1Aを使用してください。またタワーキャップ直近の中間タワーブームには、ラグ付を使用しないでください。
- 使用するガイラインの径はφ30mmです。

中間タワーの種類		
記号	タワー長さ	備考
3.0	3.0m	クレーンおよびタワー共用
6.1	6.1m	クレーンおよびタワー共用
9.1	9.1m	クレーンおよびタワー共用
9.1A	9.1m	タワー専用 (クレーンに兼用可能)

タワー長さ m (ft.)	タワー構成
30.4 (100)	
33.4 (110)	※
36.5 (120)	※
39.5 (130)	※
42.5 (140)	※
45.6 (150)	※
48.6 (160)	※
51.7 (170)	※

■タワージブ構成

- ※印は、これより短いタワージブの組立可能な構成を示します。
- 印は、ケーブルローラ取付位置を示します。
- 使用するガイラインの径はφ30mmです。

中間タワージブの種類		
記号	タワージブ長さ	備考
3.0A	3.0m	中継ジブ
3.0	3.0m	
6.1	6.1m	
9.1	9.1m	

タワー長さ m (ft.)	タワージブ構成
22.9 (75)	※
25.9 (85)	※
29.0 (95)	※
32.0 (105)	※
35.1 (115)	※
38.1 (125)	※
41.1 (135)	※
44.2 (145)	※

▶ 定格総荷重

- 定格総荷重とは、水平堅土上における転倒荷重の78%以内で、フックブロック、玉掛用ワイヤロープ等のつり具の質量を含んだ値です。
- 作業半径とはクレーン旋回中心よりつり上荷重の重心までの水平距離を意味します。
- 実際につり上げ得る荷重は定格総荷重から（主フック＋玉掛用ワイヤロープ等のつり具）の質量を差し引いた値になります。
- 定格総荷重をつる場合にも風の影響、地盤の状態、作業速度その他安全作業に有害な状況がある時はオペレータは荷重の軽減、作業速度を遅くするなど状況に応じた判断をする責任があります。
- 表中の空欄の個所では作業を行うことができません。
- クレーン作業中はガントリを最高位置に立ててください。

- すべてのタワー（ジブ）長さにおける中間タワーブーム（ジブ）の構成は取扱説明書の指示を厳守してください。
- ジブ長さ22.9mにて12.0tボールフックの使用はできません。
- ⚠ 操作ミスなどによるつり荷の落下を防ぐため、クレーン作業では自由降下（フリーフォール）作業は行わないでください。
- 巻上げロープ巻掛本数に対する最大巻上荷重とフックの質量

フック呼称		35t	12.0t (ボールフック)
最大巻上 荷重 (t)	1本掛	12.0	12.0
	2本掛	20.0	—
フック質量		0.90t	0.45t

▶タワー長さ 30.4m

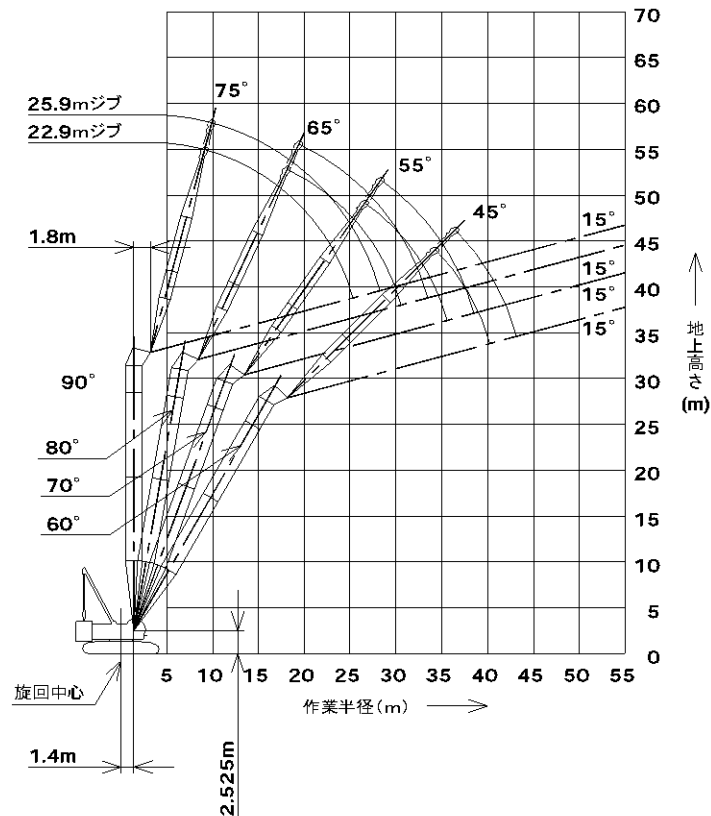

(単位:t)

タワー長さm	30.4								タワー長さm
ジブ長さm	22.9				25.9				ジブ長さm
タワー角度	90°	80°	70°	60°	90°	80°	70°	60°	タワー角度
作業半径 (m)	9.4	20.0							9.4
	10.0	20.0			20.0/10.2m				10.0
	12.0	20.0			20.0				12.0
	14.0	20.0			20.0				14.0
	15.0	20.0			20.0				15.0
	16.0	18.7			18.7				16.0
	18.0	16.6	16.3/18.4m		16.6	15.2/19.7m			18.0
	20.0	15.0	15.0		15.0	15.0			20.0
	22.0	13.3	13.6		13.6	13.6			22.0
	24.0	9.9	12.5		12.1	12.5			24.0
	26.0	7.1/25.4m	11.5	11.1/26.8m	9.5	11.5			26.0
	28.0		10.7	10.7	6.7	10.7	10.4/28.6m		28.0
	30.0		10.0	10.0	6.1/28.3m	10.0	10.0		30.0
	32.0		9.4/30.6m	9.3		9.3	9.3		32.0
	34.0			8.8	8.5/34.5m	7.7/33.5m	8.8		34.0
	36.0			8.4/35.6m	7.9		8.3	7.7/36.7m	36.0
	38.0				7.5		7.8	7.3	38.0
40.0				7.0		7.7/38.6m	6.9	40.0	
42.0				6.9/40.3m			6.4	42.0	
44.0							6.2/43.2m	44.0	

※表中の太線で囲まれた部分は、ブーム等の強度によって定められた値です。

▶タワー長さ 33.4m

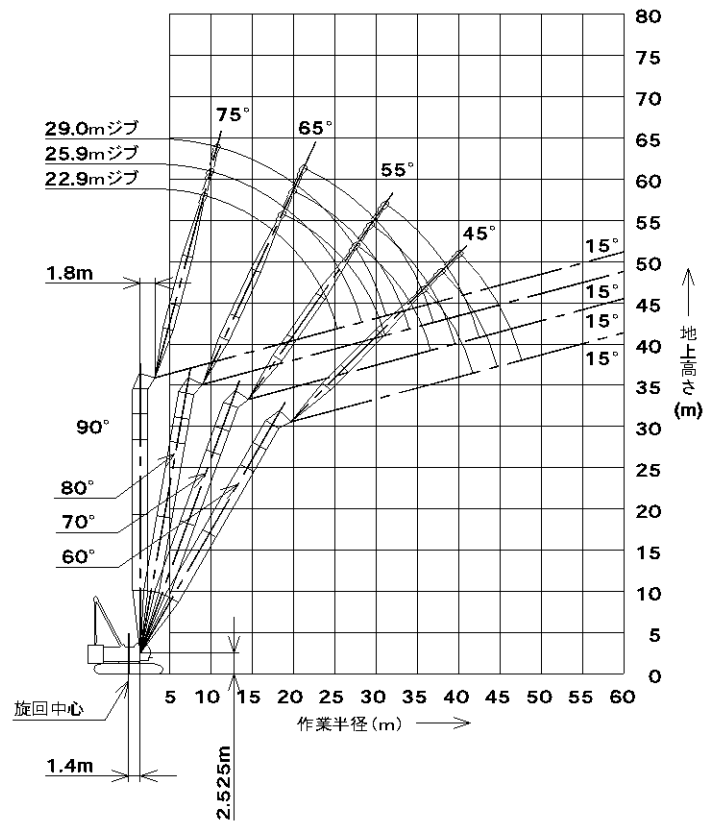

(単位:t)

タワー長さm	33.4												タワー長さm
ジブ長さm	22.9				25.9				29.0				ジブ長さm
タワー角度	90°	80°	70°	60°	90°	80°	70°	60°	90°	80°	70°	60°	タワー角度
作業半径(m)	9.4	20.0											9.4
	10.0	20.0			20.0/10.2m				20.0/11.0m				10.0
	12.0	20.0			20.0				20.0				12.0
	14.0	20.0			20.0				20.0				14.0
	15.0	20.0			20.0				20.0				15.0
	16.0	18.7			18.7				18.7				16.0
	18.0	16.6	15.8/18.9m		16.6				16.6				18.0
	20.0	15.0	15.0		15.0	14.8/20.2m			15.0	13.9/21.5m			20.0
	22.0	13.4	13.6		13.6	13.6			13.6	13.6			22.0
	24.0	10.0	12.5		12.3	12.5			12.5	12.5			24.0
	26.0	7.2/25.4m	11.5	10.7/27.9m	9.7	11.5			11.2	11.5			26.0
	28.0		10.7	10.7	6.9	10.7	10.1/29.6m		9.1	10.7			28.0
	30.0		10.0	10.0	6.2/28.3m	10.0	10.0		7.0	10.0	9.5/31.4m		30.0
	32.0		9.5/31.1m	9.3		9.3	9.3		5.3/31.2m	9.3	9.3		32.0
	34.0			8.8		8.6	8.8			8.8	8.8		34.0
	36.0			8.3	7.6	8.1/34.1m	8.3			8.3	8.3		36.0
	38.0			8.1/36.7m	7.0		7.8	6.9/38.2m		7.0/37.0m	7.8		38.0
	40.0				6.6		7.5/39.8m	6.4			7.4	6.3/40.3m	40.0
	42.0				6.2/41.8m			6.1			6.9	5.8	42.0
	44.0							5.7			6.8/42.6m	5.6	44.0
46.0							5.6/44.8m				5.2	46.0	
48.0											5.0/47.7m	48.0	

※表中の太線で囲まれた部分は、ブーム等の強度によって定められた値です。

▶タワー長さ 36.5m

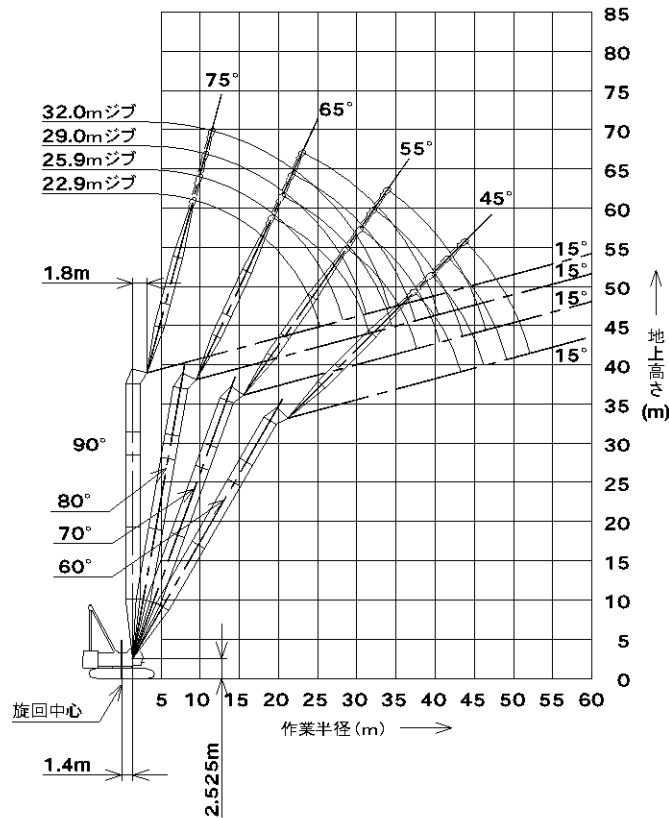

(単位:t)

タワー長さm	36.5																タワー長さm
ジブ長さm	22.9				25.9				29.0				32.0				ジブ長さm
タワー角度	90°	80°	70°	60°	90°	80°	70°	60°	90°	80°	70°	60°	90°	80°	70°	60°	タワー角度
作業半径 (m)	9.4	20.0															9.4
	10.0	20.0			20.0/10.2m				20.0/11.0m				20.0/11.8m				10.0
	12.0	20.0			20.0				20.0				20.0				12.0
	14.0	20.0			20.0				20.0				19.6				14.0
	15.0	20.0			20.0				20.0				19.1				15.0
	16.0	18.7			18.7				18.7				18.6				16.0
	18.0	16.6	15.4/19.4m		16.6				16.6				16.6				18.0
	20.0	15.0	15.0		15.0	14.4/20.7m			15.0				15.0				20.0
	22.0	13.5	13.6		13.6	13.6			13.6	13.6			13.6	12.8/23.3m			22.0
	24.0	10.1	12.5		12.4	12.5			12.5	12.5			12.5	12.5			24.0
	26.0	7.3/25.4m	11.5		9.8	11.5			11.2	11.5			11.5	11.5			26.0
	28.0		10.7	10.3/28.9m	6.9	10.7			9.2	10.7			10.2	10.7			28.0
	30.0		10.0	10.0	6.3/28.3m	10.0	9.7/30.7m		7.1	10.0			8.6	10.0			30.0
	32.0		9.4/31.7m	9.3		9.3	9.3		5.4/31.2m	9.3	9.2/32.4m		6.9	9.3			32.0
	34.0			8.8		8.8	8.8			8.8	8.7		5.0	8.8	8.6/34.2m		34.0
	36.0			8.3	6.8/37.6m	8.2/34.6m	8.3			8.3	8.2		4.6/34.2m	8.3	8.0		36.0
	38.0			7.9/37.7m	6.6		7.8	6.2/39.7m		7.1/37.6m	7.7			7.8	7.6		38.0
	40.0				6.2		7.2	6.0			7.2	5.6/41.9m		7.0	7.1		40.0
	42.0				5.8		7.1/40.7m	5.7			6.7	5.5		6.2/40.5m	6.6		42.0
	44.0				5.6/43.3m			5.4			6.3/43.6m	5.2			6.2	5.0	44.0
46.0							5.0				4.9			5.9	4.7	46.0	
48.0							5.0/46.3m				4.6			5.7/46.5m	4.6	48.0	
50.0												4.4/49.2m			4.3	50.0	
52.0															4.0	52.0	
54.0															3.8/52.2m	54.0	

※表中の太線で囲まれた部分は、ブーム等の強度によって定められた値です。

▶タワー長さ 39.5m

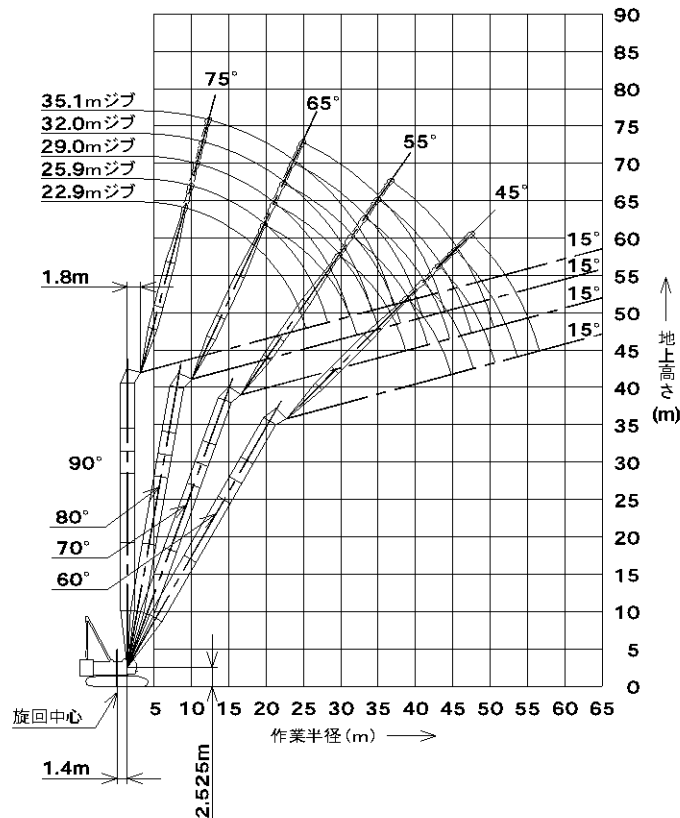

(単位:t)

タワー長さm	39.5																タワー長さm				
ジブ長さm	22.9				25.9				29.0				32.0				35.1				ジブ長さm
タワー角度	90°	80°	70°	60°	90°	80°	70°	60°	90°	80°	70°	60°	90°	80°	70°	60°	90°	80°	70°	60°	タワー角度
9.4	20.0																				9.4
10.0	20.0				20.0/10.2m				20.0/11.0m				20.0/11.8m								10.0
12.0	20.0				20.0				20.0				20.0				16.5/12.5m				12.0
14.0	20.0				20.0				20.0				19.6				16.3				14.0
15.0	20.0				20.0				20.0				19.1				16.0				15.0
16.0	18.7				18.7				18.7				18.6				15.7				16.0
18.0	16.6				16.6				16.6				16.6				15.3				18.0
20.0	15.0	15.0			15.0	14.1/21.2m			15.0				15.0				14.9				20.0
22.0	13.6	13.6			13.6	13.6			13.6	13.3/22.5m			13.6	12.6/23.8m			13.6				22.0
24.0	10.2	12.5			12.4	12.5			12.5	12.5			12.5	12.5			12.5	11.9/25.1m			24.0
26.0	7.4/25.4m	11.5			9.8	11.5			11.3	11.5			11.5	11.5			11.5	11.5			26.0
28.0		10.7			7.0	10.7			9.3	10.7			10.2	10.7			10.7	10.7			28.0
30.0		10.0	10.0		6.3/28.3m	10.0	9.4/31.7m		7.2	10.0			8.6	10.0			9.4	10.0			30.0
32.0		9.3	9.3			9.3	9.2		5.4/31.2m	9.3	8.6/33.5m		6.9	9.3			8.0	9.3			32.0
34.0		9.3/32.2m	8.7			8.8	8.6			8.8	8.4		5.0	8.8	8.0/35.2m		6.7	8.8			34.0
36.0			8.1			8.2/35.1m	8.0			8.3	7.9		4.7/34.2m	8.3	7.7		5.2	8.3	7.4/36.9m		36.0
38.0			7.5	6.0/39.1m			7.5			7.5	7.3			7.8	7.2		4.1/37.1m	7.8	7.0		38.0
40.0			7.3/38.8m	5.7			7.0	5.3/41.2m		7.1/38.1m	6.9			7.4	6.8			7.5	6.7		40.0
42.0				5.4			6.5/41.7m	5.2		6.4	4.7/43.4m			6.2/41.0m	6.3			7.1	6.3		42.0
44.0				5.1				5.0		6.0	4.7				6.0	4.3/45.5m		5.4	5.9		44.0
46.0				4.8/44.9m				4.7		5.9/44.6m	4.5				5.6	4.3		5.5	4.0/47.7m		46.0
48.0							4.4/47.8m				4.3				5.3/47.6m	4.2		5.2	4.0		48.0
50.0											4.0					3.9		4.9	3.8		50.0
52.0											3.9/50.8m					3.7		4.8/50.5m	3.6		52.0
54.0																	3.5/53.7m			3.4	54.0
56.0																				3.2	56.0
58.0																				3.1/56.6m	58.0

※表中の太線で囲まれた部分は、ブーム等の強度によって定められた値です。

▶タワー長さ 42.5m

(単位:t)

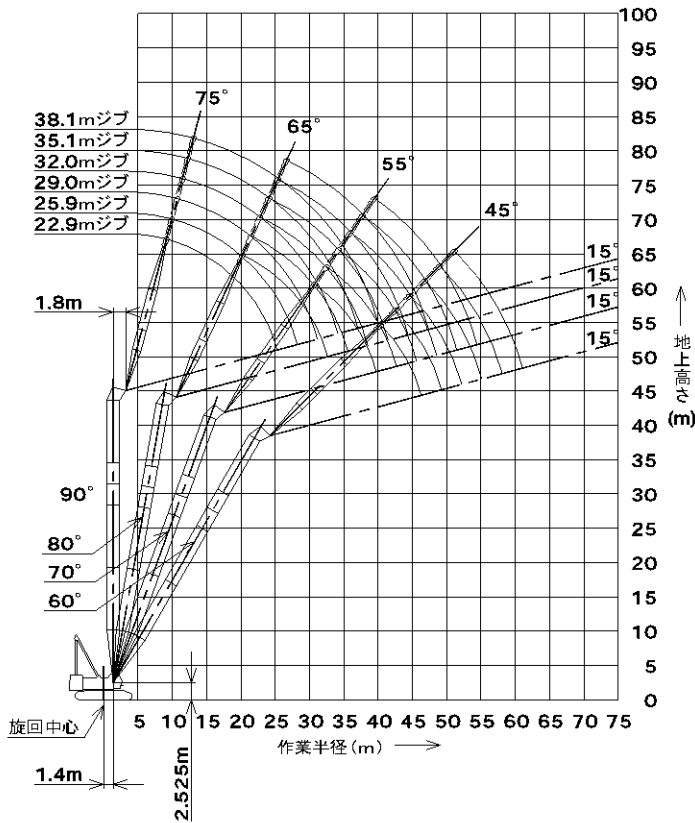

タワー長さm	42.5				タワー長さm
ジブ長さm	22.9				ジブ長さm
タワー角度	90°	80°	70°	60°	タワー角度
9.4	20.0				9.4
10.0	20.0				10.0
12.0	20.0				12.0
14.0	20.0				14.0
15.0	20.0				15.0
16.0	18.7				16.0
18.0	16.6				18.0
20.0	15.0	14.6/20.5m			20.0
22.0	13.6	13.6			22.0
24.0	10.3	12.5			24.0
26.0	7.5/25.4m	11.5			26.0
28.0		10.7			28.0
30.0		10.0	9.5/31.0m		30.0
32.0		9.3	9.0		32.0
34.0		9.1/32.7m	8.4		34.0
36.0			7.8		36.0
38.0			7.3		38.0
40.0			6.8/39.8m	5.2/40.6m	40.0
42.0				5.0	42.0
44.0				4.7	44.0
46.0				4.4	46.0
48.0				4.3/46.4m	48.0
50.0					50.0
52.0					52.0
54.0					54.0
56.0					56.0
58.0					58.0
60.0					60.0

(単位:t)

タワー長さm	42.5																タワー長さm				
ジブ長さm	25.9				29.0				32.0				35.1				38.1				ジブ長さm
タワー角度	90°	80°	70°	60°	90°	80°	70°	60°	90°	80°	70°	60°	90°	80°	70°	60°	90°	80°	70°	60°	タワー角度
9.4																					9.4
10.0	20.0/10.2m				20.0/11.0m				20.0/11.8m												10.0
12.0	20.0				20.0				20.0				16.5/12.5m				13.6/13.3m				12.0
14.0	20.0				20.0				19.5				16.2				13.6				14.0
15.0	20.0				20.0				19.0				16.0				13.4				15.0
16.0	18.7				18.7				18.5				15.7				13.1				16.0
18.0	16.6				16.6				16.6				15.3				12.7				18.0
20.0	15.0	13.7/21.8m			15.0				15.0				14.8				12.3				20.0
22.0	13.6	13.6			13.6	12.9/23.1m			13.6				13.6				11.9				22.0
24.0	12.5	12.5			12.5	12.5			12.5	12.2/24.4m			12.5	11.7/25.6m			11.6				24.0
26.0	9.9	11.5			11.3	11.5			11.5	11.5			11.5	11.5			11.2	11.1/26.9m			26.0
28.0	7.1	10.7			9.3	10.7			10.3	10.7			10.7	10.7			10.5	10.7			28.0
30.0	6.4/28.3m	10.0			7.2	10.0			8.7	10.0			9.4	10.0			9.6	10.0			30.0
32.0		9.3	8.7/32.7m		6.5/31.2m	9.3			7.0	9.3			8.0	9.3			8.5	9.3			32.0
34.0		8.8	8.2			8.8	8.0/34.5m		5.1	8.8			6.7	8.8			7.4	8.8			34.0
36.0		8.2/35.7m	7.7			8.3	7.5		4.7/34.2m	8.3	7.4/36.2m		5.3	8.3			6.3	8.3			36.0
38.0			7.2			7.8	7.1			7.8	6.8		4.1/37.1m	7.8	6.8		5.1	7.8	6.3/39.7m		38.0
40.0			6.7			7.1/38.6m	6.6			7.5	6.5			7.5	6.4		3.7	7.5	6.1		40.0
42.0			6.3	4.6/42.8m			6.2			6.2/41.5m	6.1			7.1	6.0		3.5/40.1m	7.1	5.9		42.0
44.0			6.1/42.7m	4.5			5.8	4.2/44.9m			5.7			6.1	5.6			6.7	5.5		44.0
46.0				4.3			5.4/45.7m	4.1			5.4	3.8/47.1m		5.4/44.5m	5.3			5.9	5.2		46.0
48.0				4.1				3.9			5.0	3.7			5.0	3.4/49.2m		4.7/47.4m	4.9		48.0
50.0				3.9/49.3m				3.7			4.9/48.6m	3.6			4.7	3.4			4.6	3.2/51.4m	50.0
52.0								3.5				3.4			4.4/51.6m	3.3			4.3	3.1	52.0
54.0								3.4/52.3m				3.2				3.1			4.1	3.0	54.0
56.0												3.0/55.2m				2.9			3.8/54.5m	2.8	56.0
58.0																2.8				2.6	58.0
60.0																	2.7/58.2m			2.5	60.0
62.0																				2.4/61.1m	62.0

※表中の太線で囲まれた部分は、ブーム等の強度によって定められた値です。

▶タワー長さ 45.6m

(単位:t)

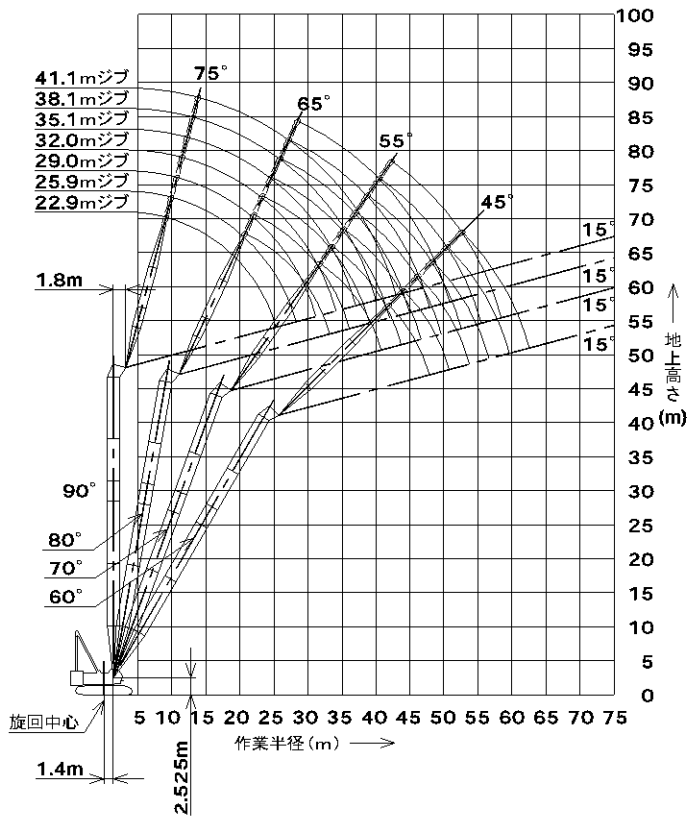

タワー長さm	45.6								タワー長さm
ジブ長さm	22.9				25.9				ジブ長さm
タワー角度	90°	80°	70°	60°	90°	80°	70°	60°	タワー角度
9.4	20.0								9.4
10.0	20.0				20.0/10.2m				10.0
12.0	20.0				20.0				12.0
14.0	20.0				20.0				14.0
15.0	20.0				20.0				15.0
16.0	18.7				18.7				16.0
18.0	16.6				16.6				18.0
20.0	15.0	14.2/21.0m			15.0				20.0
22.0	13.6	13.6			13.6	13.4/22.3m			22.0
24.0	10.3	12.5			12.5	12.5			24.0
26.0	7.5/25.4m	11.5			9.9	11.5			26.0
28.0		10.7			7.1	10.7			28.0
30.0		10.0			6.4/28.3m	10.0			30.0
32.0		9.3	8.7			9.3	8.0/33.8m		32.0
34.0		9.0/33.2m	8.0			8.8	7.8		34.0
36.0			7.5			8.3	7.4		36.0
38.0			7.0			8.2/36.2m	6.9		38.0
40.0			6.5				6.4		40.0
42.0			6.3/40.8m	4.4/42.1m			6.0		42.0
44.0				4.3			5.6/43.8m	4.0/44.3m	44.0
46.0				4.1				3.9	46.0
48.0				3.9/47.9m				3.7	48.0
50.0								3.5	50.0
52.0								3.4/50.9m	52.0
54.0									54.0
56.0									56.0
58.0									58.0
60.0									60.0

(単位:t)

タワー長さm	45.6																タワー長さm						
ジブ長さm	29.0				32.0				35.1				38.1				41.1				ジブ長さm		
タワー角度	90°	80°	70°	60°	90°	80°	70°	60°	90°	80°	70°	60°	90°	80°	70°	60°	90°	80°	70°	60°	タワー角度		
9.4																						9.4	
10.0	20.0/11.0m				20.0/11.8m																	10.0	
12.0	20.0				20.0				16.5/12.5m				13.6/13.3m									12.0	
14.0	20.0				19.5				16.2				13.6							10.7/14.1m		14.0	
15.0	20.0				19.0				16.0				13.3							10.7		15.0	
16.0	18.7				18.5				15.7				13.1							10.5		16.0	
18.0	16.6				16.6				15.2				12.7							10.2		18.0	
20.0	15.0				15.0				14.8				12.3							9.8		20.0	
22.0	13.6	12.7/23.6m			13.6				13.6				11.9							9.5		22.0	
24.0	12.5	12.5			12.5	12.0/24.9m			12.5				11.6							9.2		24.0	
26.0	11.3	11.5			11.5	11.5			11.5	11.4/26.2m			11.1	10.9/27.5m					8.9		26.0		
28.0	9.3	10.7			10.3	10.7			10.7	10.7			10.5	10.7					8.6	9.8/28.7m		28.0	
30.0	7.2	10.0			8.7	10.0			9.4	10.0			9.6	10.0					8.3	9.6		30.0	
32.0	5.5/31.2m	9.3			7.0	9.3			8.1	9.3			8.5	9.3					7.8	9.3		32.0	
34.0		8.8	7.4/35.5m		5.2	8.8			6.7	8.8			7.4	8.8					7.3	8.8		34.0	
36.0		8.3	7.1		4.8/34.2m	8.3	6.8/37.3m		5.3	8.3			6.3	8.3					6.8	8.3		36.0	
38.0		7.8	6.8			7.8	6.5		4.1/37.1m	7.8	6.3/39.0m		5.1	7.8					6.2	7.8		38.0	
40.0		7.1/39.1m	6.3			7.5	6.2			7.5	6.0		3.8	7.5	5.7/40.8m				5.2	7.5		40.0	
42.0			5.9			6.5	5.8			7.1	5.7		3.5/40.1m	7.1	5.4				4.1	7.1	5.4/42.5m	42.0	
44.0			5.5			6.2/42.1m	5.5			6.8	5.4			6.7	5.2				3.2/43.0m	6.6	5.0	44.0	
46.0			5.2	3.6/46.4m			5.1			5.4/45.0m	5.1			6.2	4.9					6.2	4.8	46.0	
48.0			5.0/46.7m	3.5			4.8	3.3/48.6m			4.8			4.7	4.6					5.8	4.5	48.0	
50.0				3.4			4.4/49.7m	3.2			4.5	3.0/50.7m			4.4					5.2	4.3	50.0	
52.0				3.2				3.1			4.2	2.9			4.1	2.7/52.9m				4.3/50.9m	4.0	52.0	
54.0				3.0/53.8m				2.9			3.9/52.6m	2.8			3.9	2.6					3.8	54.0	
56.0								2.7			2.7				3.4/55.6m	2.5					3.5	56.0	
58.0								2.6/56.7m								2.4						3.3	58.0
60.0													2.3/59.7m								3.1/58.5m	60.0	
62.0																						62.0	
64.0																						64.0	

※表中の太線で囲まれた部分は、ブーム等の強度によって定められた値です。

▶タワー長さ 48.6m

(単位:t)

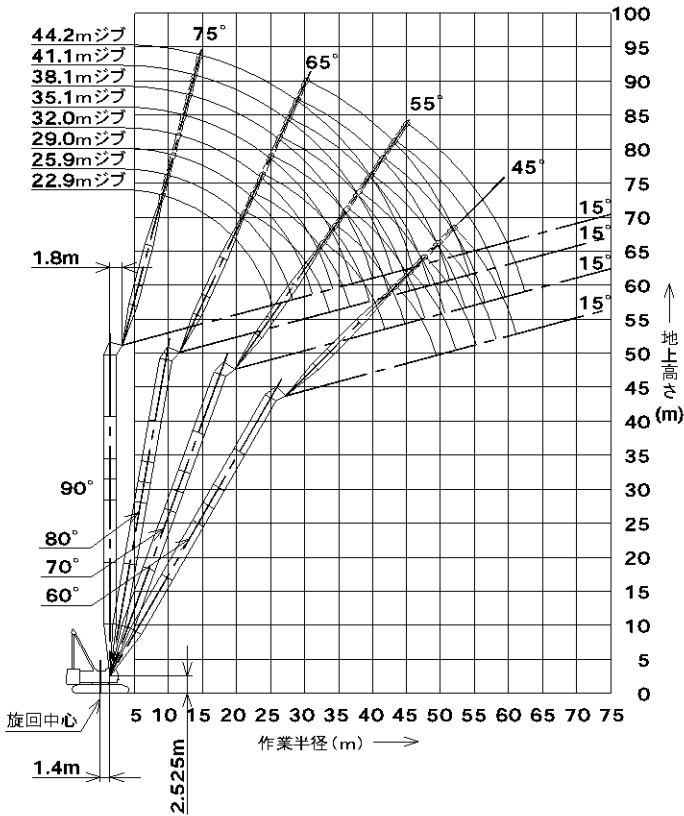

タワー長さm	48.6								タワー長さm
ジブ長さm	22.9				25.9				ジブ長さm
タワー角度	90°	80°	70°	60°	90°	80°	70°	60°	タワー角度
9.4	20.0								9.4
10.0	20.0				20.0/10.2m				10.0
12.0	20.0				20.0				12.0
14.0	20.0				20.0				14.0
15.0	20.0				19.8				15.0
16.0	18.7				18.7				16.0
18.0	16.6				16.6				18.0
20.0	15.0	13.9/21.5m			15.0				20.0
22.0	13.6	13.6			13.6	13.1/22.8m			22.0
24.0	10.4	12.5			12.5	12.5			24.0
26.0	7.5/25.4m	11.5			10.0	11.5			26.0
28.0		10.7			7.1	10.7			28.0
30.0		10.0			6.4/28.3m	10.0			30.0
32.0		9.3	8.0/33.1m			9.3			32.0
34.0		8.8/33.8m	7.6			8.8	7.4/34.8m		34.0
36.0			7.2			8.3	6.9		36.0
38.0			6.7			8.1/36.7m	6.6		38.0
40.0			6.3				6.2		40.0
42.0			5.8/41.9m	3.8/43.7m			5.8		42.0
44.0				3.8			5.4	3.4/45.8m	44.0
46.0				3.7			5.2/44.8m	3.4	46.0
48.0				3.4				3.3	48.0
50.0				3.1/49.4m				3.1	50.0
52.0								2.9	52.0
54.0								2.8/52.4m	54.0
56.0									56.0
58.0									58.0
60.0									60.0

(単位:t)

タワー長さm	48.6																		タワー長さm							
ジブ長さm	29.0				32.0				35.1				38.1				41.1				44.2				ジブ長さm	
タワー角度	90°	80°	70°	60°	90°	80°	70°	60°	90°	80°	70°	60°	90°	80°	70°	90°	80°	70°	90°	80°	70°	90°	80°	70°	タワー角度	
9.4																										9.4
10.0	20.0/11.0m				19.9/11.8m								16.5/12.5m			13.6/13.3m										10.0
12.0	20.0				19.9								16.2			13.6										12.0
14.0	19.5				18.6								16.2			13.6				10.7/14.1m			9.1/14.9m			14.0
15.0	18.9				18.0								15.9			13.3				10.7			9.1			15.0
16.0	18.3				17.5								15.7			13.1				10.5			8.9			16.0
18.0	16.6				16.5								15.2			12.7				10.1			8.6			18.0
20.0	15.0				15.0								15.2			12.3				9.8			8.3			20.0
22.0	13.6				13.6								11.9			11.9				9.5			8.0			22.0
24.0	12.5	12.4/24.1m			12.5	11.8/25.4m							12.5			11.5				9.2			7.7			24.0
26.0	11.4	11.5			11.5	11.5							11.5	11.2/26.7m		11.1				8.9			7.4			26.0
28.0	9.4	10.7			10.3	10.7							10.7	10.7		10.5	10.7			8.6	9.8/29.3m		7.2			28.0
30.0	7.3	10.0			8.7	10.0							9.4	10.0		9.6	10.0			8.3	9.6		6.9	8.0/30.6m		30.0
32.0	5.5/31.2m	9.3			7.1	9.3							8.1	9.3		8.5	9.3			7.8	9.2		6.7	7.8		32.0
34.0		8.8			5.2	8.8							6.7	8.8		7.4	8.8			7.3	8.8		6.4	7.6		34.0
36.0		8.3	6.8/36.6m		4.8/34.2m	8.3							5.3	8.3		6.3	8.3			6.8	8.3		6.0	7.3		36.0
38.0		7.8	6.3		7.8	6.2/38.3m							4.1/37.1m	7.8		5.1	7.8			6.2	7.8		5.6	7.1		38.0
40.0		7.1/39.7m	6.0		7.3	5.8							7.5	5.7/40.1m		3.8	7.5	5.2/41.8m		5.2	7.3		5.2	6.9		40.0
42.0			5.6		6.7	5.5							7.1	5.3		3.5/40.1m	6.9	5.2	4.1	6.8	4.8/43.6m		4.8	6.7		42.0
44.0			5.3		6.2/42.6m	5.2							6.5	5.1		6.5	5.0	3.2/43.0m		6.4	4.7	4.0	6.2	4.4/45.3m		44.0
46.0			5.0			4.9							6.4/45.6m	4.8		6.0	4.7			5.9	4.6	2.8	5.8	4.3		46.0
48.0			4.5/47.8m			4.6							4.5	4.4		5.5	4.4			5.5	4.3		5.5	4.1		48.0
50.0			3.0			4.3							4.2			4.7/48.5m	4.1			5.1	4.0		5.1	3.9		50.0
52.0			2.8			4.0/50.7m							4.0	2.4/52.3m			3.8			4.3/51.4m	3.7		4.7	3.6		52.0
54.0			2.6			2.5							3.5/53.7m	2.3			3.6			3.5			4.3	3.4		54.0
56.0			2.4/55.3m			2.4							2.2				3.4			3.3			3.8/54.4m	3.1		56.0
58.0						2.2							2.2				3.3/56.6m			3.0				2.9		58.0
60.0						2.1/58.3m							2.0							2.8/59.6m				2.7		60.0
62.0																								2.5		62.0
64.0																								2.4/62.5m		64.0

※表中の太線で囲まれた部分は、ブーム等の強度によって定められた値です。

▶タワー長さ 51.7m

(単位:t)

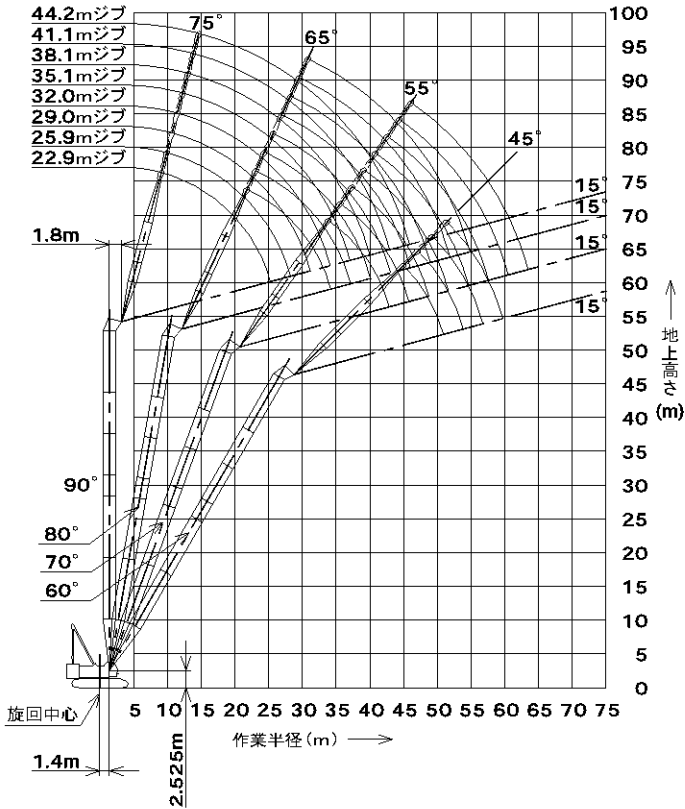

タワー長さm	51.7								タワー長さm
ジブ長さm	22.9				25.9				ジブ長さm
タワー角度	90°	80°	70°	60°	90°	80°	70°	60°	タワー角度
9.4	20.0								9.4
10.0	20.0				20.0/10.2m				10.0
12.0	20.0				20.0				12.0
14.0	20.0				19.2				14.0
15.0	20.0				18.6				15.0
16.0	18.7				18.1				16.0
18.0	16.6				16.6				18.0
20.0	15.0				15.0				20.0
22.0	13.6	13.5/22.1m			13.6	12.8/23.4m			22.0
24.0	10.4	12.5			12.5	12.5			24.0
26.0	7.6/25.4m	11.5			10.0	11.5			26.0
28.0		10.7			7.2	10.7			28.0
30.0		10.0			28.3m/6.5	10.0			30.0
32.0		9.3				9.3			32.0
34.0		8.8	7.3/34.1m			8.8	6.6/35.9m		34.0
36.0		8.7/34.3m	6.7			8.3	6.5		36.0
38.0			6.3			8.2/37.3m	6.2		38.0
40.0			5.9				5.8		40.0
42.0			5.5				5.4		42.0
44.0			5.2/42.9m	3.3/45.2m			5.1		44.0
46.0				3.2			4.8/45.9m	3.0/47.3m	46.0
48.0				3.1				2.9	48.0
50.0				2.9				2.8	50.0
52.0				2.8/51.0m				2.6	52.0
54.0								2.4/53.9m	54.0
56.0									56.0
58.0									58.0

(単位:t)

タワー長さm	51.7																		タワー長さm			
ジブ長さm	29.0			32.0			35.1			38.1			41.1			44.2			ジブ長さm			
タワー角度	90°	80°	70°	60°	90°	80°	70°	60°	90°	80°	70°	60°	90°	80°	70°	60°	90°	80°	70°	タワー角度		
9.4																					9.4	
10.0	20.0/11.0m				18.6/11.8m																10.0	
12.0	19.4				18.6				16.5/12.5m				13.6/13.3m								12.0	
14.0	18.2				17.4				16.2				13.6				10.7/14.1m			9.1/14.9m	14.0	
15.0	17.7				16.8				15.9				13.3				10.7			9.1	15.0	
16.0	17.2				16.4				15.6				13.1				10.5			8.9	16.0	
18.0	16.3				15.5				14.7				12.6				10.1			8.6	18.0	
20.0	15.0				14.7				14.0				12.2				9.8			8.3	20.0	
22.0	13.6				13.6				13.4				11.9				9.5			8.0	22.0	
24.0	12.5	12.1/24.7m			12.5	11.5/25.9m			12.5				11.5				9.1			7.7	24.0	
26.0	11.4	11.5			11.5	11.5			11.5	10.7/27.2m			11.1				8.9			7.4	26.0	
28.0	9.4	10.7			10.3	10.7			10.7	10.3			10.4	10.0/28.5m			8.6	8.5/29.8m		7.1	28.0	
30.0	7.3	10.0			8.7	10.0			9.4	9.9			9.6	9.1			8.3	8.5		6.9	8.0/31.1m	30.0
32.0	5.5/31.2m	9.3			7.1	9.3			8.1	9.3			8.5	8.8			7.8	8.2		6.7	7.6	32.0
34.0		8.8			5.2	8.8			6.8	8.8			7.4	8.5			7.3	7.9		6.4	7.3	34.0
36.0		8.3	6.0/37.6m		4.8/34.2m	8.3			5.3	8.3			6.3	8.2			6.8	7.6		6.0	7.1	36.0
38.0		7.6	5.9		7.8	5.4/39.4m			4.2/37.1m	7.8			5.2	7.7			6.3	7.4		5.6	6.8	38.0
40.0		6.9	5.7		7.4	5.4			7.3	4.9/41.1m			3.8	7.1			5.2	7.0		5.2	6.6	40.0
42.0		6.8/40.2m	5.3		6.8	5.2			6.8	4.9	3.5/40.1m		6.6	4.4/42.9m			4.1	6.5		4.8	6.4	42.0
44.0			5.0		6.2/43.1m	4.9			6.3	4.8			6.2	4.4	3.2/43.0m		6.1	4.2/44.6m		4.0	5.9	44.0
46.0			4.7			4.6			5.7	4.5			5.7	4.3			5.7	4.0	2.8	5.5	3.8/46.4m	46.0
48.0			4.4	2.6/49.5m		4.3			5.4/46.1m	4.2			5.3	4.0			5.3	3.8		5.2	3.6	48.0
50.0			4.2/48.8m	2.6		4.0	2.2/51.6m		3.9		4.7/49.0m		3.7				4.9	3.6		4.8	3.4	50.0
52.0				2.5		3.7/51.8m	2.2		3.6				3.5				4.3	3.3		4.5	3.2	52.0
54.0				2.3			2.1		3.4				3.2					3.1		4.2	3.0	54.0
56.0				2.1			2.0		3.3/54.7m				3.0					2.9		3.8/54.9m	2.8	56.0
58.0				2.0/56.8m									2.8/57.6m					2.7			2.6	58.0
60.0																		2.5			2.4	60.0
62.0																		2.4/60.6m			2.2	62.0
64.0																					2.0/63.5m	64.0

※表中の太線で囲まれた部分は、ブーム等の強度によって定められた値です。

アタッチメント

▶ クラムセル

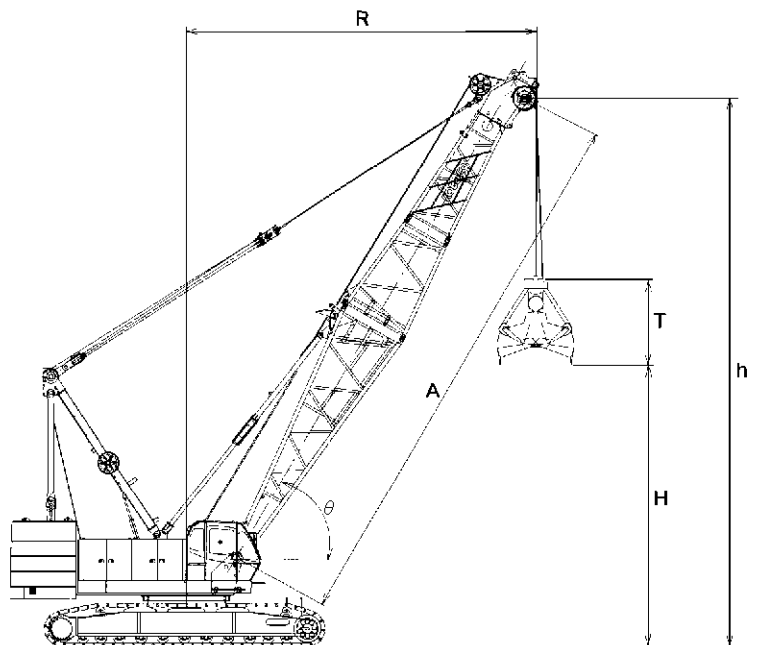

バケット開口時 高さ	バケット容量	2.0m ³	T	3.9m
		2.5m ³		4.3m
		3.0m ³		4.5m
		4.0m ³		4.7m

《注》

- ①バケットの単体質量は5.5tを超えてはいけません。
- ②バケットと掘削物の合計質量が定格総荷重を超えてはいけません。
- ③掘削物に応じて、次式により最適なバケットをお選びください。

$$\text{バケット容量(m}^3\text{)} \times \text{掘削物比重(t/m}^3\text{)} + \text{バケット質量(t)} \leq \text{定格荷重(t)}$$
 掘削物：砂、砂利、石灰石等(見掛け比重1~1.5程度)
 例) バケット容量3.0m³、バケット質量5.5tの場合

$$(\text{バケット容量}) \times (\text{掘削物比重}) + (\text{バケット質量}) \leq (\text{定格荷重})$$

$$3.0\text{m}^3 \times 1.5 + 5.5\text{t} = 10.0\text{t}$$
- ④作業サイクル、バケットの降下高さによってはバケット質量の低減が必要です。
- ⑤定格総荷重は安定度から決まっています。旋回時にブーム横引き荷重が作用するような急加速・急減速は避けてください。特にブームが長いときは注意が必要です。

ブーム長さ	m	A	15.2m					18.3m					21.3m				
ブーム角度	度	θ	36	48	58	66	70	39	48	56	64	70	40	48	55	62	68
作業半径	m	R	14.0	12.0	10.0	8.0	7.0	16.0	14.0	12.0	10.0	8.0	18.0	16.0	14.0	12.0	10.0
開口地上高さ	バケット容量	2.0m ³	4.6	7.0	8.6	9.7	10.1	7.0	9.2	10.9	12.1	13.0	9.4	11.5	13.2	14.5	15.5
		2.5m ³	4.2	6.6	8.2	9.3	9.7	6.6	8.8	10.5	11.7	12.6	9.0	11.1	12.8	14.1	15.1
		3.0m ³	4.0	6.4	8.0	9.1	9.5	6.4	8.6	10.3	11.5	12.4	8.8	10.9	12.6	13.9	14.9
		4.0m ³	3.8	6.2	7.8	8.9	9.3	6.2	8.4	10.1	11.3	12.2	8.6	10.7	12.4	13.7	14.7
ブームポイント高さ	m	h	13.3	15.6	17.2	18.5	19.0	13.3	15.6	17.2	18.5	19.0	15.7	17.9	19.5	20.8	21.8
定格総荷重	t		10.0														

ブーム長さ	m	A	24.4m					27.4m					
ブーム角度	度	θ	42	48	54	60	65	42	48	54	59	64	68
作業半径	m	R	20.0	18.0	16.0	14.0	12.0	22.0	20.0	18.0	16.0	14.0	12.0
開口地上高さ	バケット容量	2.0m ³	11.8	13.9	15.5	16.8	17.9	14.1	16.1	17.8	19.2	20.4	21.3
		2.5m ³	11.4	13.5	15.1	16.4	17.5	13.7	15.7	17.4	18.8	20.0	20.9
		3.0m ³	11.2	13.3	14.9	16.2	17.3	13.5	15.5	17.2	18.6	19.8	20.7
		4.0m ³	11.0	13.1	14.7	16.0	17.1	13.3	15.3	17.0	18.4	19.6	20.5
ブームポイント高さ	m	h	18.1	20.2	21.8	23.2	24.3	20.4	22.5	24.1	25.5	24.3	26.7
定格総荷重	t		10.0										

▶分解時の寸法・質量

- 記載の数値は参考値です。
- 一般公道での輸送に際しては関係法規を遵守してください。

▶本体

名称	寸法 (幅×高さ×長さ) mm	質量 kg
本体 (下記を含む) ・主巻ロープ 920kg ・補巻ロープ 700kg ・ブーム起伏ロープ 350kg ・燃料1/3 120kg		62,300
本体 (下記を含む、クローラ無し) ・主巻ロープ 920kg ・補巻ロープ 700kg ・ブーム起伏ロープ 350kg ・燃料1/3 120kg		33,200
本体 (下記を含まない) ・クローラ ・ガントリ ・下部スプレッダ ・ブーム起伏ロープ		30,400
クローラ	910×1,230×7,890	14,500
トランスリフタ	350×1,050×1,030	370/1基
ガントリ	1,340×985×5,800	2,200
カウンタウエイト 1	4,100×940×1,860	9,900
カウンタウエイト 2	4,100×530×1,860	10,000
カウンタウエイト 3	4,100×530×1,860	10,000
カウンタウエイト 4	4,100×530×1,860	10,000
カウンタウエイト 5R	1,430×680×1,820	6,300
カウンタウエイト 5L	1,430×680×1,815	6,100

▶アタッチメント (ガイドラインの質量は含まれていません)

名称	寸法 (幅×高さ×長さ) mm	質量 kg	名称	寸法 (幅×高さ×長さ) mm	質量 kg
上部ブーム	1,530×1,990×5,280	1,850	上部タワージブ	1,355×1,365×8,150	900
中間テーパーブーム	1,980×2,095×3,180	490	下部タワージブ	2,020×1,365×6,395	1,200
下部ブーム (タワーバックストップ付)	1,980×2,410×7,845	3,100	3.0m中継ジブ	1,530×1,365×3,145	230
3.0m中間ブーム	1,980×1,990×3,180	530	3.0m中間タワージブ	1,355×1,365×3,145	210
6.1m中間ブーム	1,980×1,990×6,230	850	6.1m中間タワージブ	1,355×1,365×6,195	360
9.1m中間ブーム	1,980×1,990×9,270	1,160	9.1m中間タワージブ	1,355×1,365×9,240	510
クレーンバックストップ	115×210×6,265	210/片側	タワージブストラット	2,065×915×5,925	1,355
上部ジブ	1,020×840×5,040	315	タワーバックストップ	140×235×6,200	420/片側
下部ジブ	1,030×840×4,757	210	クレーン上部スプレッダ	2,045×365×880	485
3.0m中間ジブ	1,020×840×3,130	110	クレーン下部スプレッダ	1,150×300×930	315
6.1m中間ジブ	1,020×840×6,175	190	タワー用上部スプレッダ	925×730×1,170	310
クレーンジブストラット	1,040×615×5,130	300	タワー用下部スプレッダ	1,940×460×1,070	410
タワーキャップ	1,990×2,065×4,875	1,780	120tフック	710×1,930×700	1,700
9.1mタワー専用 中間ブーム	1,980×2,790×9,270	1,540	70tフック	470×1,825×700	1,200
			35tフック	365×1,575×700	900
			12tボールフック	φ380×1,200	450

標準装備品

●上下部本体
φ26mmウインチ(フリーフォールなし、主巻/補巻)
カウンタウエイト 52.3t (9.9t+10.0t×3+6.3t+6.1t)
910mm幅シュー
170AHバッテリー
トランスリフタ
トラベルキット
ガントリ起伏シリンダ
電動ハンドスロットル
ブーム速度可変コントローラ
主補速度可変コントローラ
旋回中立フリー/ブレーキ切替システム
運転席サイドデッキ
左ガード昇降ステップ
クローラ昇降ステップ×4
アンチスリップシート(ガード上面)
中間ブーム足場
上部スプレッタ自動格納装置
標準工具一式
工具箱(カーボディ部および左ガード内取付)
前照灯×2
バックミラー×2
ドラムミラー
ワンウェイコイル
●運転室
エアコン
ラゲッジボックス
カップキーパ
ラジオ(FM/AM)
灰皿
シガーライター

間欠式ワイパ&ウインドウウォッシャー(天窓/前面/前面下窓)
サンバイザ
天井ブラインド
グリーンガラス
フロアマット:布製
ブレーキペダルカバー:ゴム製
靴置きトレイ
水準器
●安全装置
過負荷防止装置(ブーム巻下緩停止機能付)
過負荷防止装置解除防止キー
過巻防止装置解除防止キー
液晶マルチディスプレイ
第2過巻防止装置(ブーム角度極限停止機能)
ブーム過巻自動停止装置(緩停止機能付)
フック過巻自動停止装置
ブームバックストップ
乗降遮断式レバーロック
走行レバーロック
手動式ドラムパウル(主巻/補巻)
手動式ドラムロック(ブーム起伏)
中立時ネガブレーキ(主巻/補巻/ブーム起伏/走行)
旋回中立フリー/ブレーキ切替表示灯
旋回中立フリー/ブレーキ切替スイッチ(ロック機構付)
油圧安全弁(主巻/補巻/ブーム起伏/走行)
ホーン
マルチボイスアラーム:過巻/過負荷
旋回ブレーキロック
旋回ロック(全周4ヶ所)
旋回フラッシュ/ブザー

オプション装備品

φ26mmウインチ(フリーフォール付き、主巻/補巻)
中立フリーボイスアラーム(主巻/補巻)
サードドラム:ワイヤロープφ26×240m、フリーフォールなし
リーピングウインチ:ワイヤロープφ8×260m
油圧式タグライン:ワイヤロープφ10×45m
カウンタウエイト吊り用ワイヤ
自立用敷板
フットアクセル:case1-右側、case2-左右両側
ブーム起伏ペダル:右側
ドラム回転計/反力感知装置(主巻/補巻)
キャブ天井ガード
キャブ上面ガード
全周サイドデッキ(手すり付)
ガード上面手すり(折りたたみ式、右ガード梯子付)
ブーム背面全長足場(アルミ製)
ブーム上面脱着式手摺(スタンションバー)

上部ブーム(タワージブ)腹面保護材
定格総荷重表示看板:下部ブーム腹面
ブーム看板(上部ブーム用、中間ブーム用)
差込式社名看板
後方確認カメラ&モニタ(カラー)
主・補ドラム監視カメラ&モニタ(カラー)
ブームドラム監視カメラ&モニタ(カラー)
過負荷外部表示灯(角型3色灯)
揚程・深度表示装置
警報付風速計
航空障害灯
外部音声アラーム:走行/旋回
電動式燃料給油ポンプ
消火器
扇風機